

CASE JOINT HARDWARE CGLC/CGMC

Instructions for the hardware used to join Guardian Merchandiser® CGLC/CGMC cases together in a lineup. Read the Installation & Operation Manual for full installation instructions.

Part Number	Description	Quantity
64-0034	3/8" Washer	9
64-0064	3/8" Hex Nut	4
64-0287	3/8-16 x 1" Hex Bolt	5
72-0321	Vertical Joining Splice	1

FIGURE 1: Joining Hardware

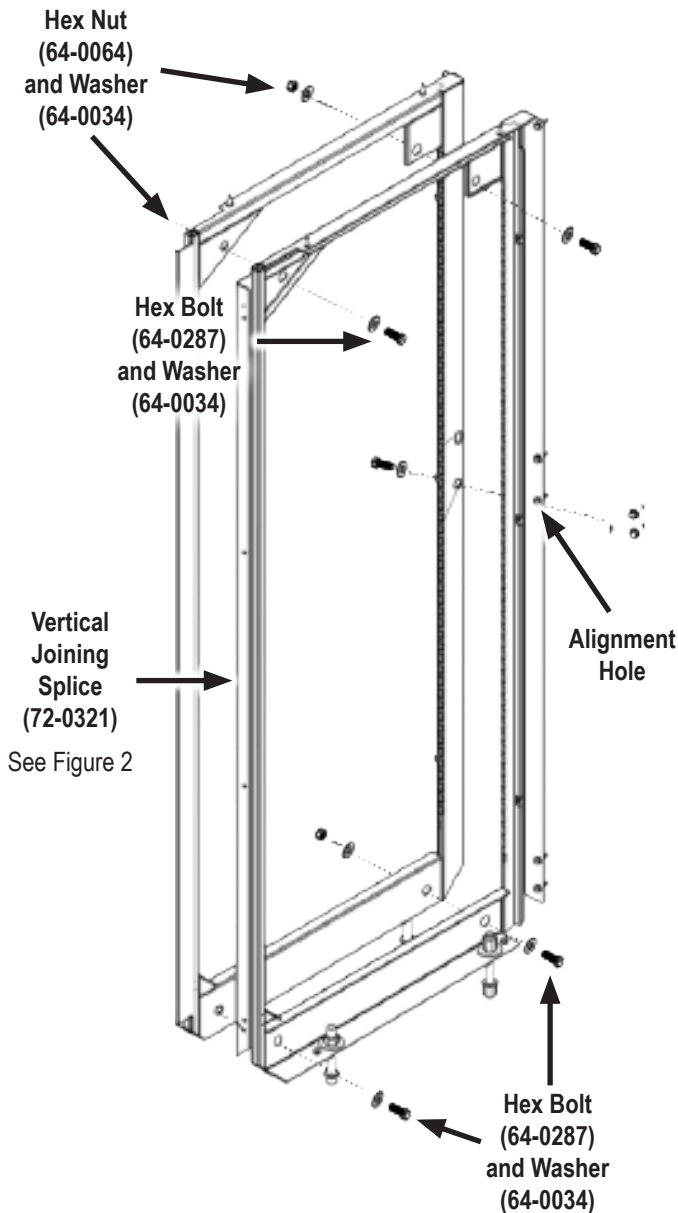

1. Level and shim cases. Cases must be level, square, and straight with shims placed under ALL bases.
2. Prepare one of the two cases with Butyl caulk. Refer to the case caulking instructions shipped with the case or in the Installation & Operation Manual.
3. Slide the cases together.
4. To access joining holes, remove shelves, bottom wire rack, and rear duct cover from the right end of the left case. Remove the bottom wire rack from the left end of the right case.
5. Align cases front and rear, and make sure cases are within 1/4" from one another. Use a drift pin or screwdriver in the alignment holes in the rear end frames near the joining holes.
6. Install and hand tighten the joining bolts (64-0287), nuts (64-0064), and washers (64-0034) at each corner. Begin at the top rear, working down the back of the case and up the front, making sure that the seams are flush. **Do not pull cases together using the joining bolts (See Figure 1).**
7. Install a bolt and washer at the middle joining slot, which goes into a weldnut in the adjacent end frame. This weldnut makes it possible to join the cases without removing the rear duct or shelves from the right case at the joint (See Figure 1).
8. Tighten all joining bolts, using torque 70-85 in-lbs.
9. The vertical joining splice (72-0321) is shipped separately with the roll guards. Install it by snapping it onto the end mullions of the adjacent cases (See Figure 2). Position it to cover from the bottom of the mullion to just under the top of the case.

FIGURE 2: Vertical Joining Splice (V-Strip, Top View)

