

REVEAL

merchandiser®



ZERO ZONE

REVEAL MERCHANDISER® OPEN MULTI-DECKS

With ChillBrite® LED Lighting

INSTALLATION & OPERATION MANUAL



AHRI CERTIFIED®
www.ahridirectory.org

Commercial Refrigerated Display Merchandisers
and Storage Cabinets
AHRI Standard 1200

DOE
COMPLIANT

66-0057 REV J • JAN 2026

NSF



Intertek

Table of Contents

ZERO ZONE WARRANTY	1
INTRODUCTION	2
INSTALLATION & OPERATION	4
■ Delivery Inspection.....	4
■ Packaging.....	4
■ Location.....	4
■ Moving Cases.....	5
■ Optional Bases.....	5
■ Leveling.....	6
■ Lineup Assembly.....	8
■ Case Joint Caulking (Butyl*).....	9
■ NSF Compliance Sealing (Silicone).....	10
■ Reveal to Reveal with Doors Joint Instructions.....	11
■ Canopy Splice.....	12
■ Hand Rail Splice.....	12
■ Alternate Bumper Splice & Glass Front Splice.....	13
■ Drain.....	13
■ Kickplates.....	14
■ Bumper.....	14
■ Mirrors.....	15
■ Night Curtains.....	16
■ Under Shelf Lights.....	16
■ Canopy Lights.....	17
■ Quick-Connect Spray Hose.....	17
■ Shelves & Stocking Product.....	18
■ Adjustable Bottom Rack.....	19
REFRIGERATION	20
■ Mechanical Components.....	20
■ Evaporator Coil & Expansion Valve.....	20
■ Evaporator Fans.....	20
■ Refrigerant Piping.....	20
■ Operation Set Points.....	21
■ Case Thermometer.....	21
■ Off-Cycle Defrost.....	22
ELECTRICAL	23
■ General.....	23
■ Controller Sensor Wires.....	24
MAINTENANCE	25
■ Cleaning.....	25
■ Under Case Floor Cleaning (NSF).....	25

When installing a Reveal Merchandiser® in a Hybrid™ configuration, refer to both this manual and the Hybrid™ Installation & Operation Manual.

ZERO ZONE WARRANTY

Limited Warranty

Zero Zone, Inc. (Seller) hereby warrants that any products manufactured by it and sold are warranted to be free from defects in material and workmanship, under normal use and service for its intended purpose, for a period of one (1) year from the date of original installation (not to exceed 15 months from the date of factory shipment). Zero Zone ChillBrite® LED Lighting carries a 5-year parts warranty. Zero Zone CoolView® Doors carry a 10-year glass pack parts warranty. The obligation under this warranty shall be limited to repairing or exchanging any part, or parts, FOB Factory, which is proven to the satisfaction of the Zero Zone Service Department to be defective. Zero Zone reserves the right to inspect the job site, installation, and reason for failure. This limited warranty does not cover labor, freight, or loss of food or product, including refrigerant loss. This warranty does not apply to motors, switches, controls, lamps, driers, fuses, or other parts manufactured by others and purchased by the Seller unless the manufacturer of these items warrants the same to the Seller, and then only to the extent of those manufacturer's warranty to the Seller. Any products sold on an "AS IS" basis shall not be covered by this warranty.

Extended Warranties

In addition to the standard limited warranty, for further consideration, the Seller will extend to the original purchaser prior to shipment, a limited extended warranty on the compressor only, following expiration of the standard warranty. The Seller agrees to repair or exchange, at its option, or provide reimbursement for such exchange as directed, less any credit allowed for return of the original compressor, of a compressor of like or similar design and capacity, if it is shown to the satisfaction of Zero Zone that the compressor is inoperative due to defects in factory workmanship or material under normal use and services as outlined by Zero Zone in its Installation & Operation Manuals and other instructions.

Length of Extended Warranty

Any compressor warranty may be extended for an additional four (4) years, but such extension must be purchased prior to shipment to be effective. This warranty is only for the compressor and not for any other associated parts of the refrigeration system.

Product Not Manufactured by the Seller

The written warranty, if any, provided by the manufacturer of any part of the refrigeration unit sold by Seller to Buyer, but not manufactured by Seller, is hereby assigned to the Buyer. However, Seller makes no representation or warranty regarding the existence, validity, or enforceability of any such written warranty.

Limitation and Exclusion of Warranties

THE WARRANTIES SET FORTH HEREIN ARE EXCLUSIVE AND IN LIEU OF ALL OTHER WARRANTIES AND REMEDIES WHATSOEVER, INCLUDING, BUT NOT LIMITED TO, IMPLIED WARRANTIES OF MERCHANTABILITY AND/OR FITNESS FOR A PARTICULAR PURPOSE.

INTRODUCTION

Important User Information

Copyright © 2026 Zero Zone, Inc.

All rights reserved. No part of the contents of this manual may be reproduced, copied, or transmitted in any form or by any means including graphic, electronic, or mechanical methods or photocopying, recording, or information storage and retrieval systems without the written permission of the publisher, Zero Zone, unless it is for the purchaser's personal use.

The information in this manual is subject to change without notice and does not represent a commitment on the part of Zero Zone. Zero Zone does not assume any responsibility for any errors that may appear in this manual. In no event will Zero Zone be liable for technical or editorial omissions made herein, nor for direct, indirect, special, incidental, or consequential damages resulting from the use or defect of this manual.

The information in this document is not intended to cover all possible conditions and situations that might occur. The end user must exercise caution and common sense when installing, using, or maintaining Zero Zone products. Zero Zone products should only be installed by qualified, professional refrigeration technicians. If any questions or problems arise, call Zero Zone at 800-247-4496.

Any change to a Zero Zone product made during the installation, start-up, or at any other time must be submitted in writing to Zero Zone for approval and be approved by Zero Zone in writing prior to commission. The product warranty is voided when any unapproved change is made to a Zero Zone product.

Manufacturer

Zero Zone, Inc.

110 N Oakridge Dr • North Prairie, WI 53153 • 800-247-4496 • www.zero-zone.com

Intended Use

Zero Zone products are intended to be installed and used as described in this manual and other related Zero Zone literature, specifications, drawings, and data. All Zero Zone products must be leveled after being installed.

This appliance is not intended for use by persons (including children) with reduced physical, sensory, or mental capabilities, or lack of experience and knowledge, unless they have been given supervision or instruction concerning use of the appliance by a person responsible for their safety. Children should be supervised to ensure that they do not play with the appliance.

Do not store explosive substances such as aerosol cans with a flammable propellant in this appliance.

Testing Standards

These display cases were designed and tested using the following industry standards:

- NSF 7 – Commercial Refrigerators and Freezers (ANSI Approved) (equipment certified by NSF)
- NSF 51 – Food Equipment Materials (ANSI Approved) (equipment certified by NSF)
- UL 471 – Commercial Refrigerators and Freezers (ANSI Approved) (equipment certified by ETL)
- ASHRAE Standard 72 – Method of Testing Commercial Refrigerators and Freezers (ANSI Approved)
- AHRI 1200 – Performance Rating of Commercial Refrigerated Display Merchandisers and Storage Cabinets (ANSI Approved)
- DOE Compliant (All U.S. Sales and U.S. Territories)

ASHRAE Standard 72 specifies the test conditions for the equipment. It includes the ambient conditions of 75°F dry bulb and 55% RH. Consult the factory if your store exceeds these test conditions.

INTRODUCTION

Display Case Models

The information contained in this manual pertains to the following Zero Zone display cases:

CASE MODEL	DESCRIPTION	SILL HEIGHTS
ORMC82	82" Standard Multi-Deck (5-Deck)	Low (L), Medium (M), or High (H) Sills
ORMC87	87" Tall Multi-Deck (6-Deck)	Low (L), Medium (M), or High (H) Sills
ORMC75-MX	75" Meat Exclusive Multi-Deck (4-Deck)	Low (L) or Medium (M) Sills
ORMC80-MX	80" Meat Exclusive Multi-Deck (4-Deck)	Low (L) or Medium (M) Sills
ORMC80-PX	80" Produce Exclusive Multi-Deck (3-Deck)	Low (L) or Medium (M) Sills
ORMC82-PX	82" Produce Exclusive Multi-Deck (3-Deck)	Low (L) or Medium (M) Sills

Case Features

Zero Zone produces high quality refrigerated display cases using state-of-the-art components, including a high efficiency evaporator coil. Case features may include:

- Electronic fan motors
- Zero Zone ChillBrite® LED Lighting
- Mirrors
- Night Curtains
- Quick-Connect Spray Hose
- 90-bar rating available for CO₂ display cases

INSTALLATION & OPERATION



CAUTION!

DO NOT STAND ON TOP OF A REVEAL MERCHANDISER®. THE TOP OF THE CASE IS NOT DESIGNED TO SUPPORT THE WEIGHT OF A PERSON.

Delivery Inspection

Zero Zone display cases are carefully factory-tested, inspected, and packed to ensure delivery in the best possible condition. The equipment should be unwrapped and checked for damage immediately upon delivery. **DAMAGE MUST BE NOTED AT TIME OF DELIVERY, AND ALL CLAIMS FOR DAMAGES MUST BE FILED WITH THE TRANSPORTATION COMPANY, NOT WITH ZERO ZONE.** The carrier will supply necessary report and claim forms. Contact your Zero Zone sales representative or the service department to arrange for replacement parts.

Do not leave, store, or hold case outdoors in direct sunlight or high ambient temperature. This could potentially cause any plastic inside the case to deform or warp.

Note: The installation of the appliance and the refrigerant unit must only be made by the manufacturer's service personnel or suitably qualified person.

Packaging

IMPORTANT: The hand rail, canopy, and honeycomb holder are shipped with protective coating. Do not remove this coating until cases are completely installed. Wooden supports are used for shipping cases without end panels. These can be removed after moving the case into position.

Each **case** in a lineup is labeled to identify the **lineup** and **joint**. The label uses a 2-digit number designation, separated by a decimal. The first number indicates the case lineup. The second number indicates the case joint. Case joints begin with the number “1” at the left-most joint in the lineup when looking at the front of the lineup. The first case in the lineup will be labeled on the right end and the second case in the lineup will be labeled on the left end. The numbers on each end to be joined will match (**See Figure 1**).

FIGURE 1: Case Label Information

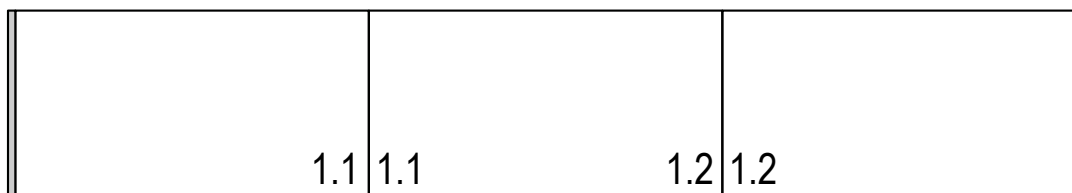

Front of Lineup

The *first* case in a lineup (with the right side labeled “x.1”) has a packet attached to the shelving that contains touch-up paint. *Every* case in a lineup has a packet attached to the shelving that contains important information about the case and/or lineup and, if applicable, special instructions for installing ordered options.

Bumpers and kickplates are shipped on top of the case. Shelves for the case are tie-wrapped and blocked into the individual cases. Other accessories like drain traps, drain pans, condensate evaporation pans, and hat channel rails are shipped in the case that require the parts.

Materials for joining cases—including caulk, joining bolts, splices, and end filler posts—are shipped in each case to be joined.

Location

These cases must not be installed in the direct rays of the sun or near a source of radiant heat. Be certain that the floor under the installation is of sufficient strength to prevent sagging. Uneven surfaces will result in reduced performance.

Cases should be set to allow a minimum 3" of space behind the back of the units. This will allow necessary air to circulate behind the display cases and prevent condensation. Higher humidity stores with minimal air circulation require at least a 4" gap. A minimum 2" gap is recommended between cases on end-to-end installations. All minimum spacing requirements may increase if seismic restraints are used.

Building soffits must be set back at least 6" from the front of the cases to allow access to electrical wiring on the top of the case.

INSTALLATION & OPERATION

Moving Cases

Various tools and equipment may be used to move cases, including, but not limited to, a forklift, a Johnson bar, a pallet jack, furniture rollers, casters, or a Rol-A-Lift. Be careful to avoid damaging the store flooring. Only certified forklift drivers should use forklifts to move the cases. The case should only be lifted off the floor as high as necessary for transport. The forklift should be driven slowly; avoid abrupt motions or bumps.

- Use the end frame to push/pull the case.
- When using a Johnson bar, only contact the sheet metal of the bottom foamed panel. **Do not contact the bumper support. Be careful not to pierce the sheet metal with the corner of the Johnson bar.**
- When using a pallet jack or furniture rollers, only place them under the floor panels. **Do not place them under the bumper support or drain pipe as that will crush the components.**
- Cases have steel protective support plates under the end panels (not under insulated dividers) to protect them from Johnson bar damage.

Make sure that a forklift with the proper fork dimensions is available. **Forks must be 48" long, 1 1/2" to 1 3/4" thick, and no more than 4" wide to fit the bases.** Refer to the table below for instructions.

CASE MODEL	INSTRUCTIONS
4ORMC	Forks must extend 20" to 24" under the case from either end
6ORMC	Forks must extend 26" to 30" under the case from either end
8ORMC	Forks must extend 39" to 43" under the case from either end
12ORMC	Forks must extend 44" to 47" under the case from either end

OPTIONAL BASES

For low shipping height applications, such as 80" tall doorways, Zero Zone offers 1" bases or 1 3/4" bases.

- Cases with 1" bases will be shipped on a wooden pallet and are not forkliftable. The case can be removed from the pallet to slide it through the 80" doorway.
- The 1 3/4" bases are expandable to accommodate up to 1 3/4" thick forks (See Figure 2). To use a forklift on the expandable bases, raise the case with a Johnson bar and place wooden blocks under the case, allowing the base to expand enough for forks to be inserted.

Cases with 1" or 1 3/4" bases will be set into nested bases (See Figure 3). The drain elbow will be shipped loose and must be installed using extra thick PVC cement after the case set in place.

Spacer blocks (also called filler blocks) are included in the end bases of 8' and 12' cases that use bases which are 4 1/2" or taller. These blocks limit the case's forward tilt while it is being lifted by a forklift. The forks should be inserted above the spacer blocks (See Figure 4).

FIGURE 2: Expandable Base

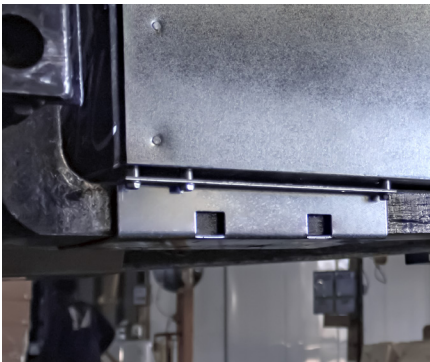

FIGURE 3: Nested Base

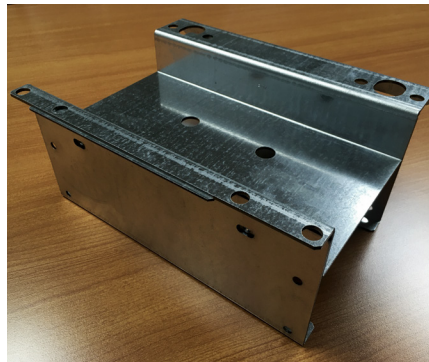
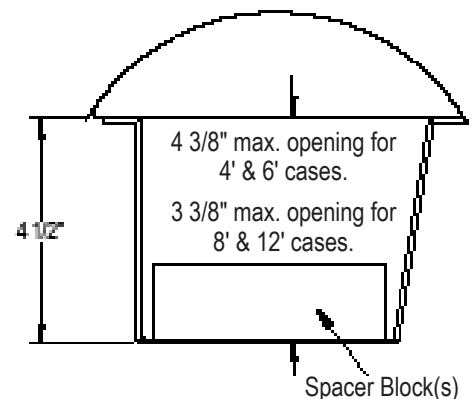

FIGURE 4: Spacer Block



INSTALLATION & OPERATION

Leveling

Cases should be set level right to left to allow complete drainage of defrost and condensate water. Since a level floor area is seldom available, the following steps are recommended to ensure a level installation. If your case uses seismic restraints, specific instructions for attaching seismic restraints are included in your document package. Read and understand these instructions before assembling the lineup.

1. Measure off and mark on the floor the exact dimensions of the case lineup (**See Figure 5**). Refer to the fixture plan or floor plan.
2. Snap a chalk line at the locations for the front and back positions of the bases.
3. Mark locations of all joints, both front and back.
4. Using a laser level or transit, find the highest point along both base position lines. Using the high point as a reference, mark the difference directly on the floor to each base, both front and back (**See Figure 6**).

FIGURE 5: Measure and Mark Exact Case Outline



FIGURE 6: Mark Floor Level Difference

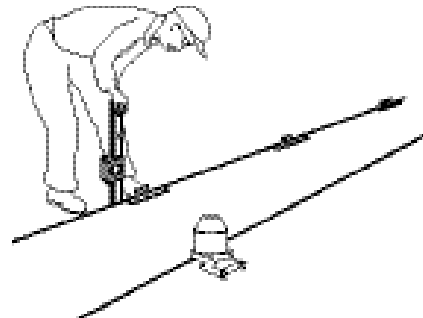

5. Place enough shims under each base to equal the highest point. Shims should not extend beyond the front case bases or they will interfere with installing trim. The shims should be oriented to sit under the front and rear bends of each base. Tape all shims in place (**See Figure 7**). After the case is set, additional shims may need to be added at specific base locations (**See Figure 9 on page 7**).

FIGURE 7: Tape Shims on the Floor Under Each Base

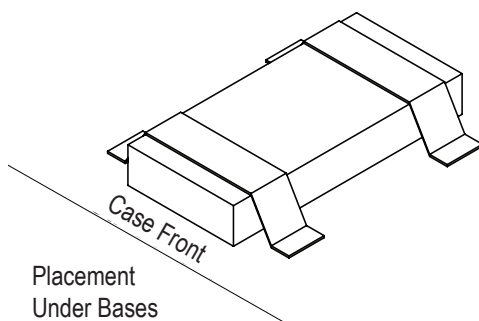
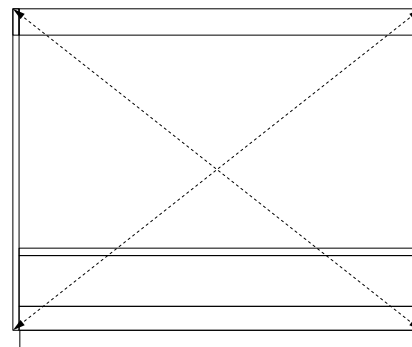

FIGURE 8: Case Squareness



6. The case must be leveled front-to-back and side-to-side. Ensure that the case is set square to within 1/8". Measure squareness from the top right corner to the bottom left corner, and then again from the top left corner to the bottom right corner. Measurements should be equal (**See Figure 8**). Check that the case is level by setting a 4' level against the frame or intermediate standard.
7. Cases should be set with a slight backward tilt to offset the forward lean of a fully loaded case. We recommend an additional 3/8" of shims be installed under the front bases after the case is leveled.
8. Place additional support shims under any bases with gaps taller than one shim. **Note: Total height of shims should be less than 3/4".**

INSTALLATION & OPERATION

FIGURE 9: Reveal Merchandiser® Base Locations

Drawings are top views with bases shown under the case. The front of the case is toward the bottom of the page.
Case length does not include end panels (1 1/2" wide each).

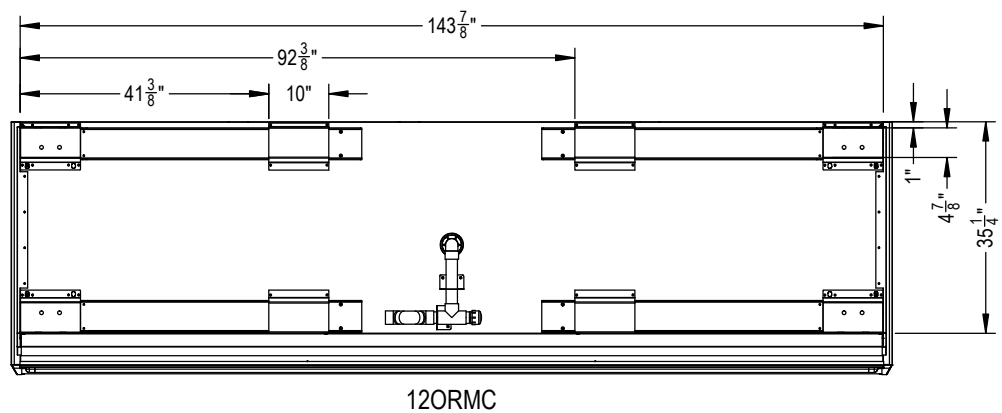
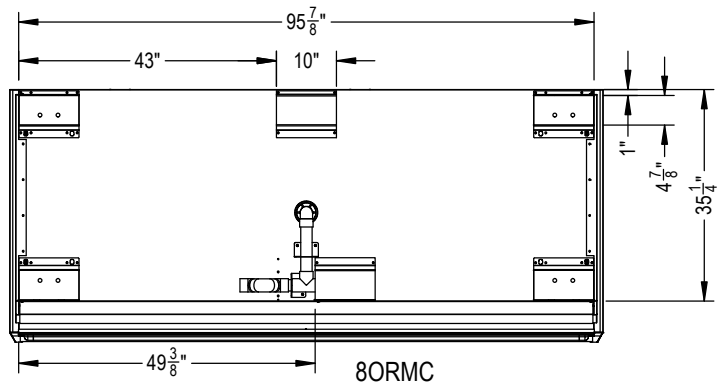
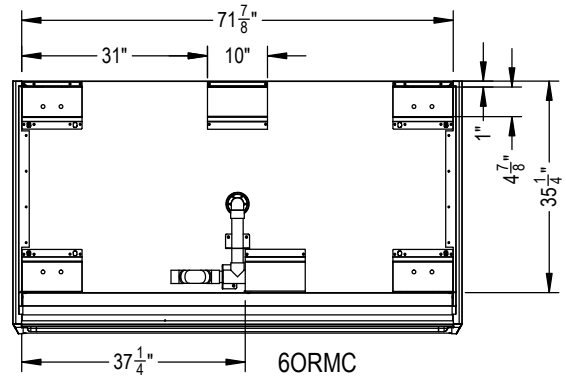
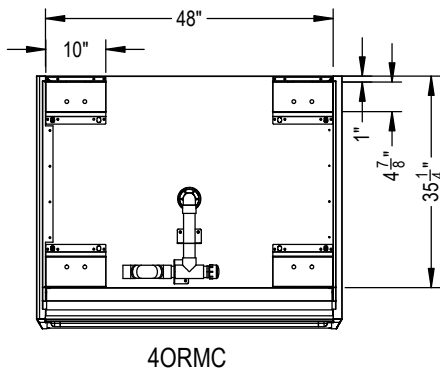

INSTALLATION & OPERATION

Lineup Assembly

Zero Zone display cases have been designed for continuous display so that multiple cases may be joined together to create a lineup of any desired length. The cases will be ready for assembly after removing the packaging material. However, do not remove the protective coating on the hand rail, canopy, and honeycomb holder at this time.

A case lineup must be properly aligned, which starts with properly leveling the case (See "Leveling" on page 6). It is crucial to use a laser level to measure the high points in the floor and properly shim each base location.

Before joining cases, remove all shipping blocks inside the bases and the steel support braces under the end panels. There are bolts that go up through the support plates into the underside of the foamed floor.

A case must be prepared with Butyl caulk before setting the next case in the lineup. Case caulking instructions and caulk are shipped with every case (See Figure 12 on page 9).

Move the next case into position within 1/4" of the first case. Align the joining holes using a drift pin or screwdriver through the joining holes. Bolt the cases together using the provided joining hardware (See Figure 10 and Figure 11). Begin tightening the bolts at the top rear, working down the back of the case and to the bottom front, making sure that the case seams are flush. **Do not pull cases together using joining bolts.**

The interior case seams must be sealed using silicone sealant for NSF compliance (See Figure 13 on page 10). Do not allow Butyl caulk and silicone sealant to contact one another as this may affect adhesion or color of each.

FIGURE 10: Case Joining Hardware

Only showing end frames of cases

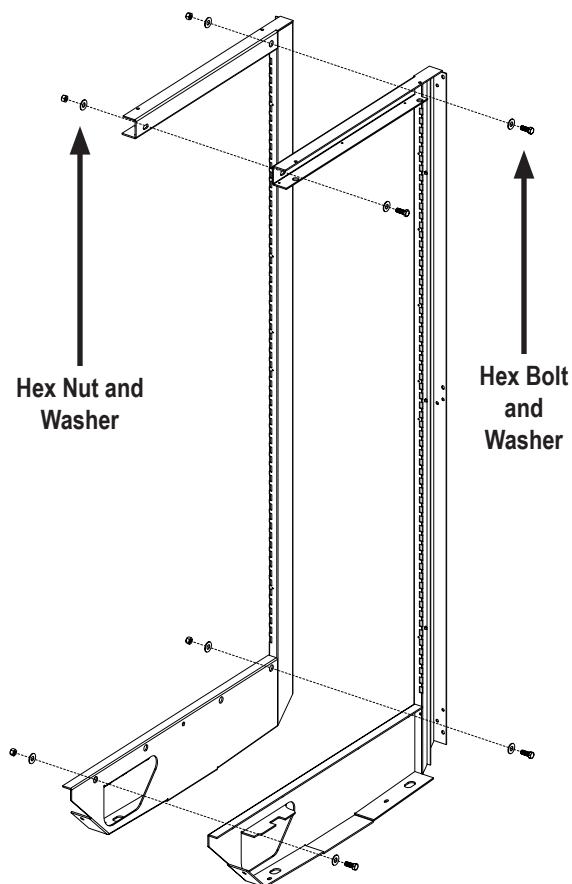

3/8-16 x 1" hex bolts (4), 3/8" hex nuts (4), 3/8" washers (8)

FIGURE 11: Case Joining Hardware with Insulated Divider

Only showing end frames of cases

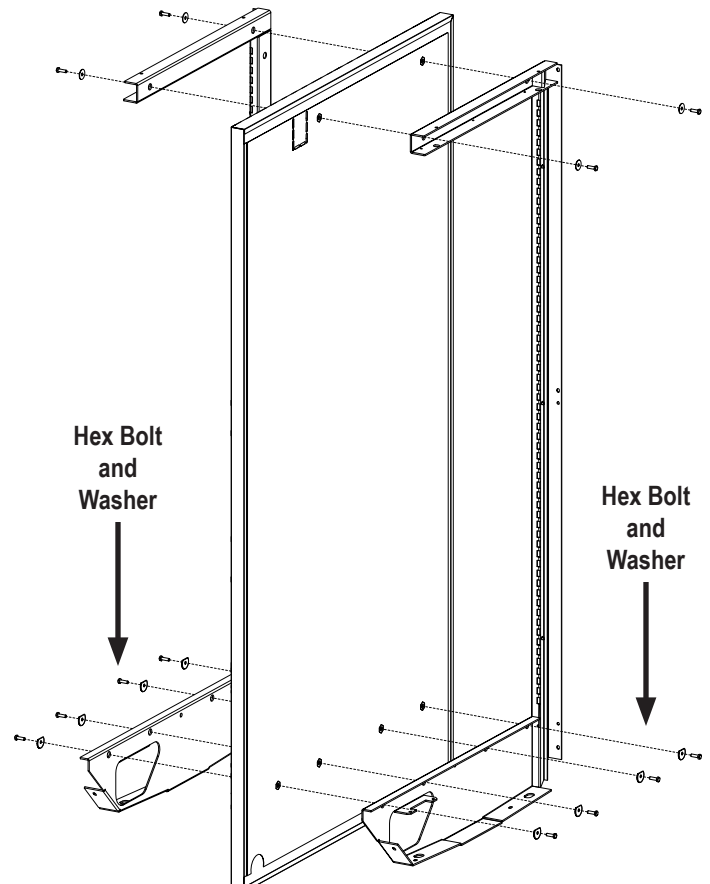

1/4-20 x 7/8" hex bolts (12), 1/4" washers (12)

INSTALLATION & OPERATION

Before joining the cases, remove all packaging material on the display case, including any spacer blocks inside the bases. Repeat caulking between each case in the lineup.

FIGURE 12: Case Joint Caulking (Butyl*)

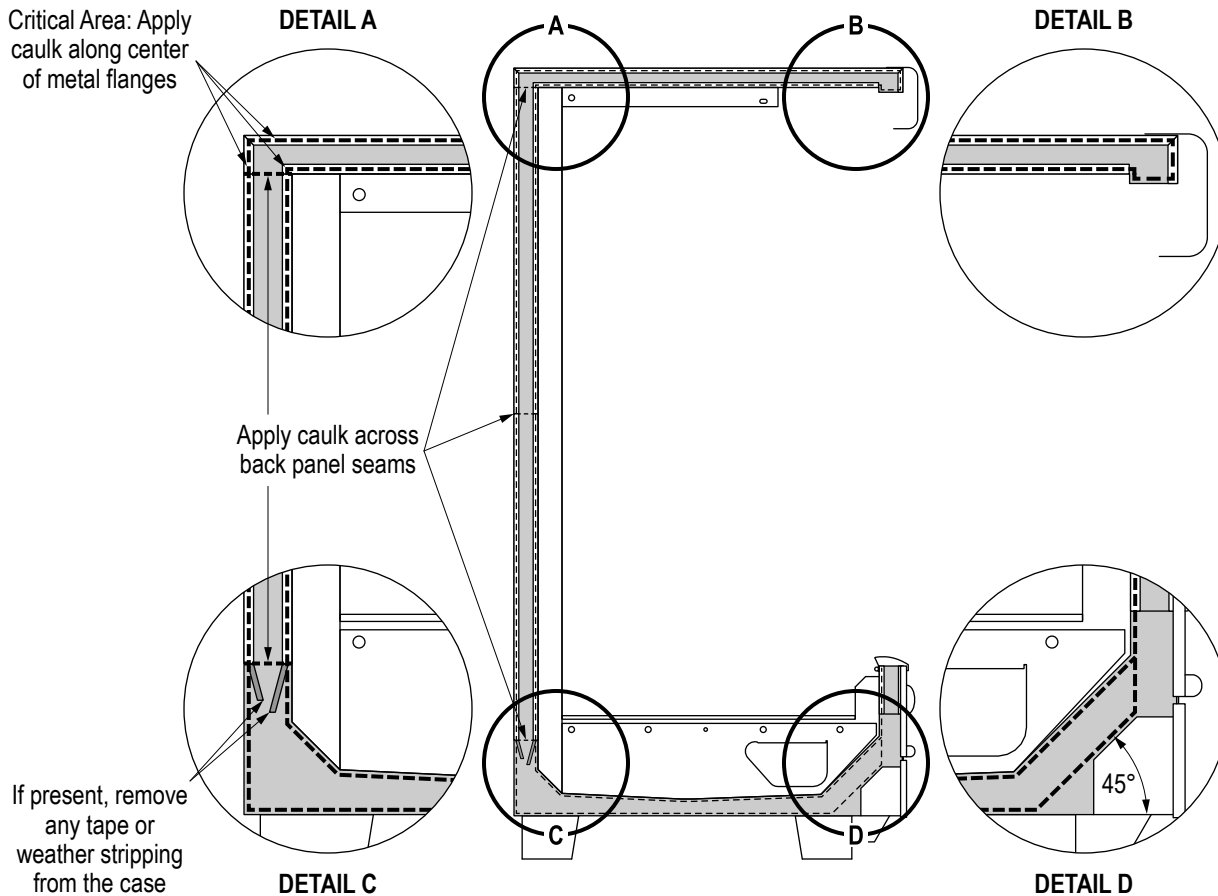

IT IS CRITICAL TO FOLLOW THIS PROCEDURE TO ENSURE CASES ARE PROPERLY SEALED.

SURFACES TO BE CAULKED MUST BE CLEAN, DRY, FREE OF TAPE/ADHESIVE, AND FREE OF FROST (ABOVE 40°F).

Note: Apply Butyl caulk to only one case—not both cases. The caulk will spread out when the cases are pushed together, and excessive caulk may squeeze out of the joint. Wipe away any caulk that squeezes out. Butyl caulk will not mix with silicone sealant (used for NSF sealing), which will affect adhesion of both.

1. Remove all shipping material. This includes packaging and packing tape.
2. Apply 1/2" thick beads of Butyl caulk* along the ceiling, rear wall, and the bottom of the case where indicated by the dashed lines in the drawing. Caulk must be continuous with no gaps. Always apply 2 beads where specified.
3. After cases are joined and tightened, caulk the top and back exterior seams, if accessible, to ensure a tight seal.
4. **See Figure 13 on page 10** for information about NSF compliance sealing with silicone sealant.

*DO NOT APPLY BUTYL CAULK ON SEAFOOD OR BAKERY CASES. Butyl caulk never cures and emits vapors that affect seafood and bakery products. Recommended alternative caulk: Polyurethane-based (full curing, durable, moisture-activated) or silicone-based (full curing).

INSTALLATION & OPERATION

FIGURE 13: NSF Compliance Sealing (Silicone)

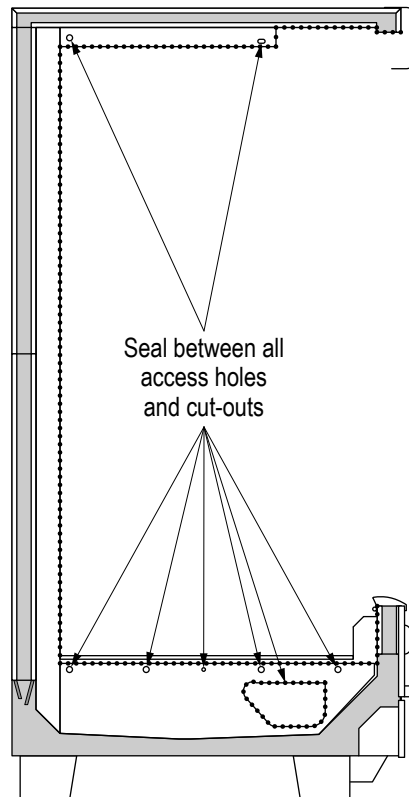

THIS PROCEDURE MUST BE FOLLOWED FOR NSF COMPLIANCE.

SURFACES TO BE SEALED MUST BE CLEAN, DRY, FREE OF BUTYL CAULK, AND FREE OF FROST (ABOVE 40°F).

Note: Cases must be properly caulked and joined before NSF sealing. Wipe away any Butyl caulk that squeezes out of the case joint. Butyl caulk and silicone sealant will not mix, which affects the adhesion of both. (See Figure 12 on page 9).

1. Apply silicone-based sealant in small, continuous beads where indicated by the dotted lines in the drawing. Do not thin or feather, as that will affect adhesion.
2. Sealant must be added between cases at case joints, between a case and an end panel, and between all access holes and cut-outs in the case end frame.

INSTALLATION & OPERATION

Reveal to Reveal with Doors Joint Instructions

CAUTION! THE INSULATED DIVIDER PANEL IS SHIPPED INSTALLED ON THE REVEAL WITH DOORS CASE. DO NOT REMOVE ALL (3) BOLTS NOTED IN FIGURE 14 AT THE SAME TIME! AT ALL TIMES, AT LEAST TWO BOLTS (THROUGH OR SHORT) MUST BE THROUGH THE CASE END FRAME AND INTO THE PANEL TO PREVENT THE PANEL FROM SHIFTING OUT OF POSITION.

Note: The images shown provide reference for the Reveal (open) display case being installed to the left of the Reveal with Doors display case when viewing from the front. The view will be opposite for Reveal (open) display case to be installed to the right of the Reveal with Doors display case.

1. Remove a joint mounting bolt and washer from one location shown in **Figure 14** and drill a 5/16" hole through the insulated divider panel from outside the Reveal with Doors display case.
2. From inside the Reveal with Doors display case, push the removed bolt through its original hole in the end frame and into the hole drilled in step 1.
3. Repeat steps 1 and 2 for the remaining two bolts, then proceed to step 4.
4. After the Reveal with Doors display case is set, remove the bolts reinserted per step 2 by pushing the supplied through bolts (with washers) into the drilled holes from inside the Reveal (open) display case one at a time (See **Figure 16**). Inside the Reveal with Doors display case, install nuts and washers on all (3) through bolts and torque the nuts to 60 lbs-in. Washers **must** be used under each bolt head and under each nut.
5. From inside the Reveal (open) display case, install short (removed) bolts and washers in the locations indicated in Views 2 (See **Figure 15**). Washers **must** be used under each bolt head. Torque the bolts to 60 lbs-in.

FIGURE 14: Drill Locations
View of left end from inside Reveal with Doors display case

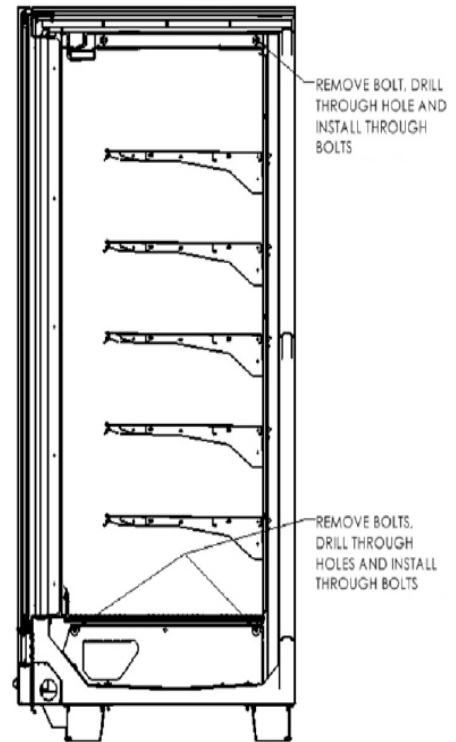

FIGURE 15: Short Bolt Installation
View of right end from inside Reveal with Doors display case

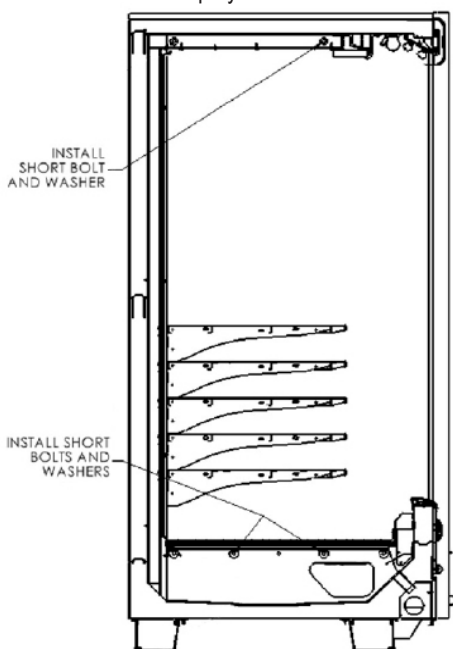
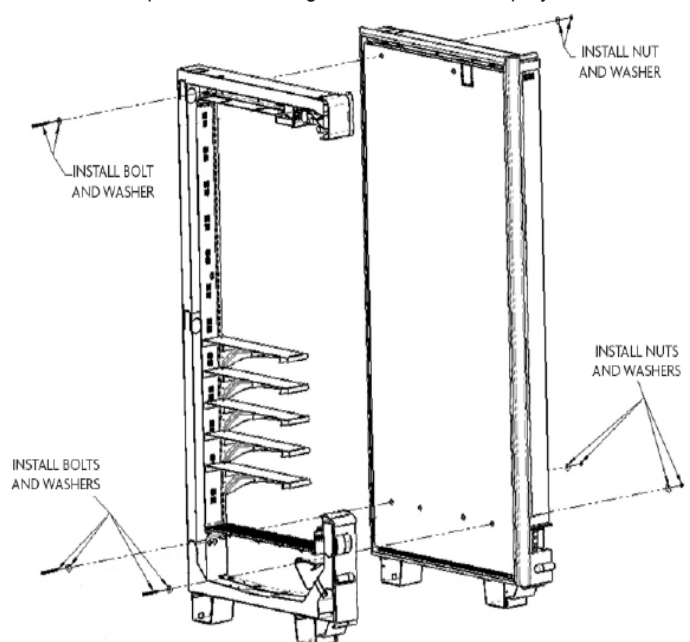

FIGURE 16: Through Bolt Installation
Exploded view of right end of Reveal display case



INSTALLATION & OPERATION

Canopy Splice

A ceiling alignment bracket must be field-installed to align the ceiling panels prior to canopy alignment. The canopy will come with factory-installed end caps on the first and last cases in a lineup. At each case joint, a canopy splice will need to be installed (See Figure 17).

On cases with aluminum canopies, the factory-installed splice must be aligned in the field. Use a rubber mallet to slide the canopy splice over to the adjacent canopy until the canopies are aligned. You may need to loosen the canopy screws if canopies are not within 3/8".

On cases with angled sheet metal canopies, the splice is shipped loose. Fit it over both canopies and screw into place.

**FIGURE 17: Ceiling Alignment Bracket and Canopy Splice
(Aluminum on Left, Stainless Steel on Right)**

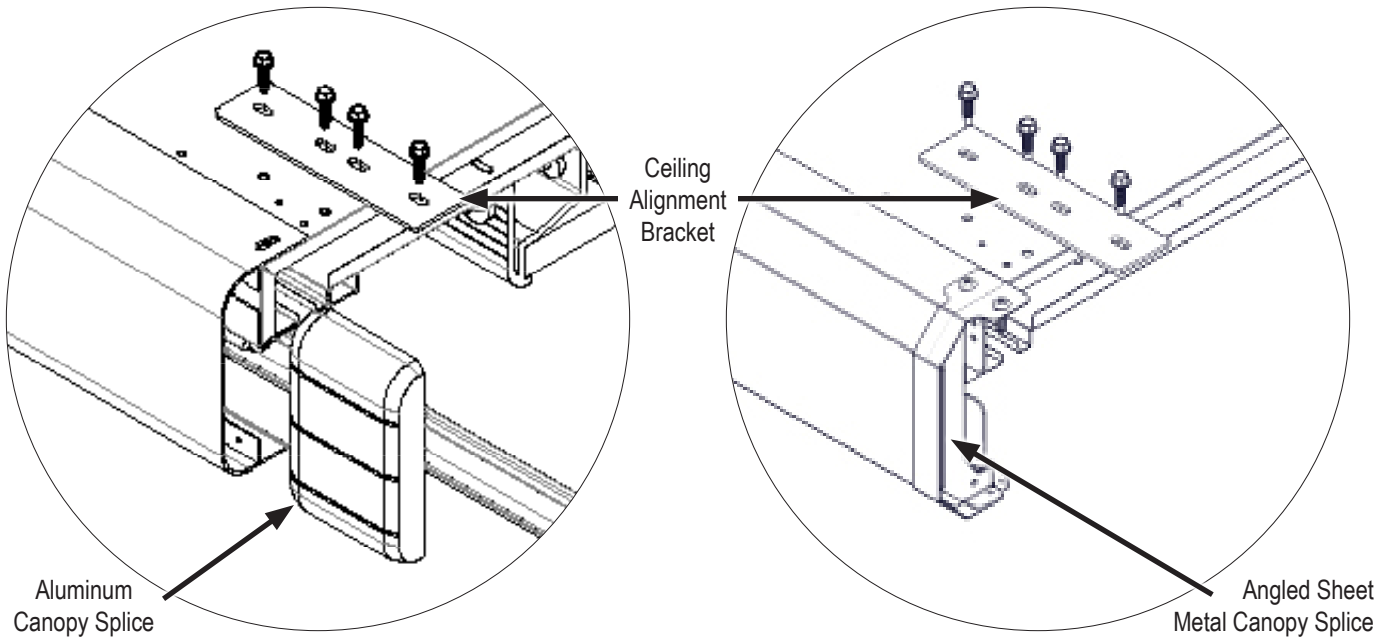

Hand Rail Splice

Some cases will have the standard bumper and handrail. When joining these cases, insert the front of the hand rail trim splice into the slot at the front bottom of the hand rail (See Figure 18). Form the trim piece over the hand rail and fasten it in the back (See Figure 19).

FIGURE 18: Hand Rail Trim (Front)



FIGURE 19: Hand Rail Trim (Back)



INSTALLATION & OPERATION

Alternate Bumper Splice & Glass Front Splice

Some cases have an alternate bumper, which may include an optional glass front. When joining these cases together, special splice pieces will be provided. First, hook the bumper splice over the bumper and fasten it under the bumper so it covers the seam. Next, install the cap splice or the glass front splice. The cap splice hooks over the back of the handrail and fastens inside the case and into the bumper splice (See Figure 20). The glass front splice slides down over the glass and fastens inside the case (See Figure 21).

FIGURE 20: Splices for Alternate Bumper with Cap

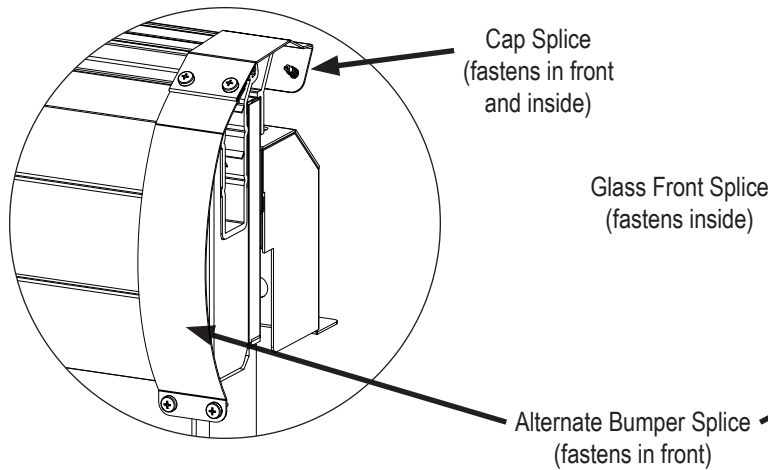
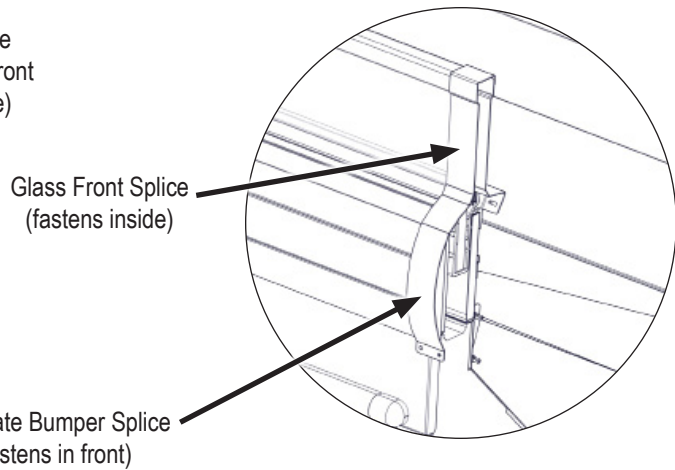

FIGURE 21: Splices for Alternate Bumper with Glass



Drain

The drain can be accessed through the drain access port in the center of the floor pan in the bottom of the case (See Figure 22). The 1 1/2" PVC drain outlet is located at the center front of the case behind the kickplate.

The drain line exits the case in the center. The lateral runs of drain pipe should be installed through the bases. There is no room in front of the base for the drain pipe because the kickplate installs directly to the front of the bases.

Reveal cases include a factory-installed positioning bracket just to the left of the drain lateral (See Figure 23). Either the drain trap or the clean-out plug are installed to the left of the tee through the positioning bracket. This helps ensure proper alignment of the drain.

Install the drain tee to the drain lateral pipe, aligning the left-facing opening on the tee with the hole in the positioning bracket (See Figure 24). The drain trap may be installed to the left or right opening on the tee to reach the store floor drain. Install the clean-out plug to the other side of the tee. The drain trap must be level. Prime the trap with water after installation. The drain line must be pitched away from the case enough to ensure proper drainage. Consult your local codes for minimum requirements.

FIGURE 22: Drain Access Port

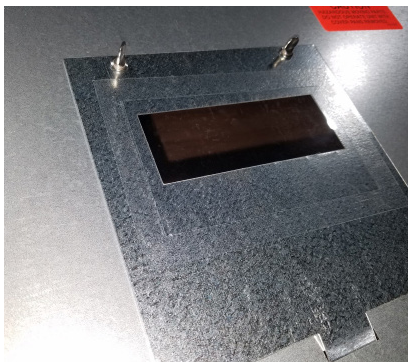

FIGURE 23: Drain as Shipped

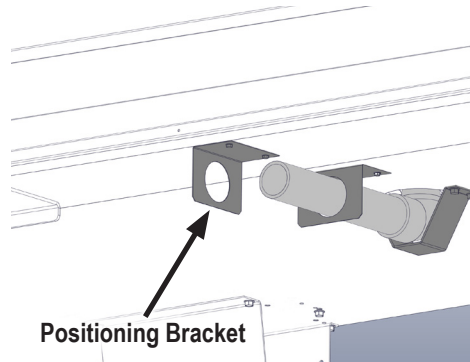
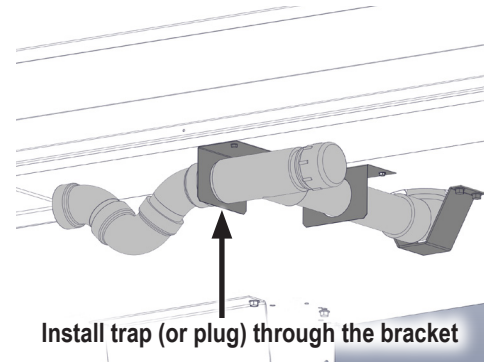

FIGURE 24: Drain Installed (Trap to Left Shown)



INSTALLATION & OPERATION

Kickplates

Each case is shipped with a front kickplate. Cases with end panels are shipped with 1 side kickplate per end panel. Cases that join together are shipped with a kickplate splice.

For a standard Reveal™ case (ORMC82) or a Reveal™ Tall case (ORMC87), front and side kickplates are attached to the case bases using Tinnerman clips. Position the front kickplate so the flange is on top and facing outward. The screw (supplied) goes through the kickplate and into the Tinnerman clip (**See Figure 25**).

A 2-piece kickplate is used on the Reveal™ Meat Exclusive (ORMC75-MX and ORMC80-MX) and the Reveal™ Produce Exclusive (ORMC80-PX and ORMC82-PX). First, position the lower kickplate flush with the bottom of the bases and fasten it to the bases. Second, position the upper kickplate under the case and fasten it to the bases through the lower kickplate. This will create a continuous kickplate.

There is a natural gap between the top of the kickplate and the underside of the Reveal Merchandiser® that allows airflow of 20 CFM/foot. If more airflow is required, contact the factory to order optional louvered kickplates (provides 60 CFM/foot).

FIGURE 25: Kickplate Installation

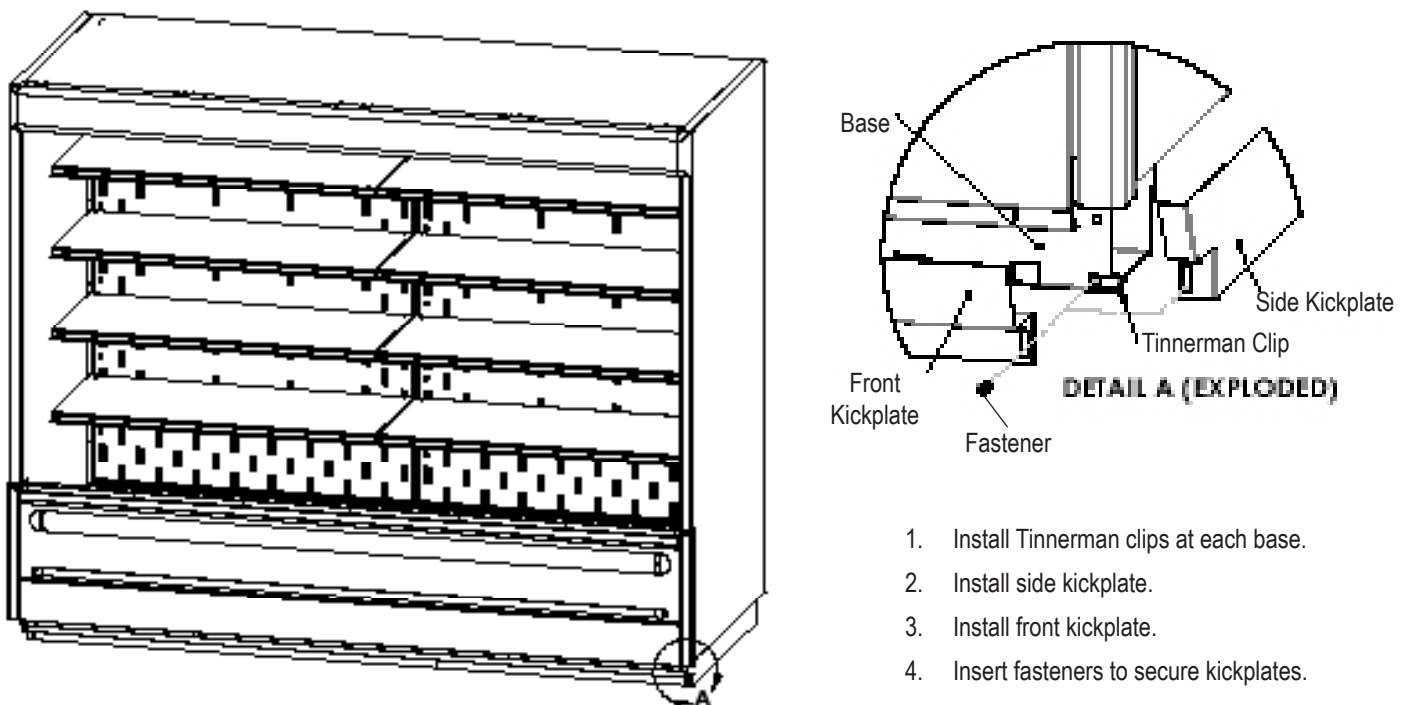

Bumper

Cases are supplied with a protective bumper. Most bumpers will be factory-installed to the bumper support and snap track. If a continuous bumper is used, only the bumper support and snap track will be installed. The continuous bumper may need to be trimmed before snapping it onto the snap track.

INSTALLATION & OPERATION

Mirrors

Mirror assemblies include the mirrors, brackets, supports, and an air deflector, which are shipped together as a kit.

1. Assemble the support brackets to the mirror support. Slide the tabs on the brackets into the slots in the mirror support. Use the supplied hex screws to fasten the brackets in place (See Figure 26 on page 15). **Note: There will be 3 brackets and 3 screws for 36" wide mirrors or 4 brackets and 4 screws for 48" wide mirrors.**

FIGURE 26: Support Brackets and Mirror Support

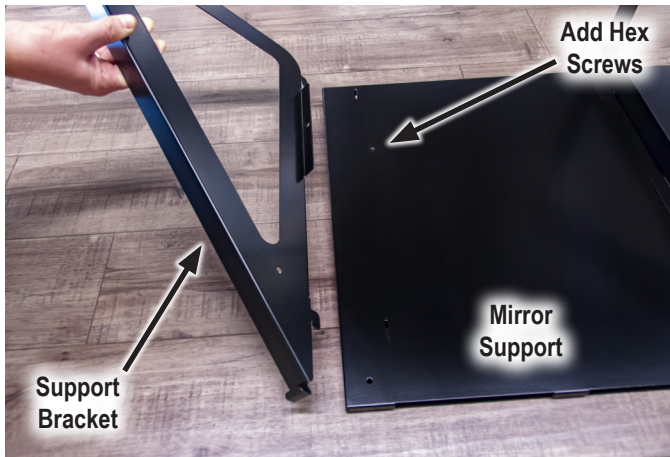

FIGURE 27: Install Mirror Support into the Shelf Standards



2. Install the mirror support into the shelf standards, using both the second and third slots from the top (See Figure 27 on page 15).
3. Install the air deflector (also called a "mirror scoop") into the shelf standards under the mirror support. Refer to the table for the correct slot, counting down from the top (See Figure 28 on page 15 and Figure 29 on page 15).

FIGURE 28: Shelf Standard Slots for Air Deflector

MIRROR HEIGHT	SLOT FOR AIR DEFLECTOR
8" Tall	6th Slot from Top
12" Tall	9th Slot from Top
20" Tall	16th Slot from Top
24" Tall	19th Slot from Top

FIGURE 29: Install Air Deflector Under Mirror Support



FIGURE 30: Hang the Mirror, Insert Top First



INSTALLATION & OPERATION

4. Peel the protective coating off of the mirror. Hang the mirror from the brackets. Start by inserting it into the top and then the bottom (**See Figure 30 on page 15**).
5. Center the mirror for optimal product display.

Night Curtains

Cases ordered with night curtains will have factory-installed mounting brackets. A retrofit kit must be ordered from Zero Zone to install onto a case that was not ordered with night curtains.

Some night curtains pull down and lock into position like roller window blinds. Other night curtains use a magnet and attach to the metal kickplate. If the night curtain has a magnet, orientate the night curtain so the magnet can attach to the case.

Tip the night curtain forward into the mounting bracket and twist it until you hear a click as the brackets engage (**See Figure 31**). Once installed, the night curtain can be pulled down (**See Figure 32**).

Under Shelf Lights

1. Position the under shelf light on the bottom of the shelf with the cord towards the left side of the shelf (**See Figure 36 on page 17**).
2. Attach the under shelf light to the shelf using the magnets that built into the light stick body.

FIGURE 31: Install Night Curtain into the Brackets



FIGURE 32: Night Curtain Pulled Down



3. After installing the shelf, plug the cord into the nearest duct pocket under the shelf (**See Figure 37 on page 17**).
4. Mount the cord to the shelf bracket. Slide and rotate the magnets on the cord as needed.

INSTALLATION & OPERATION

FIGURE 36: Install Light Under the Shelf

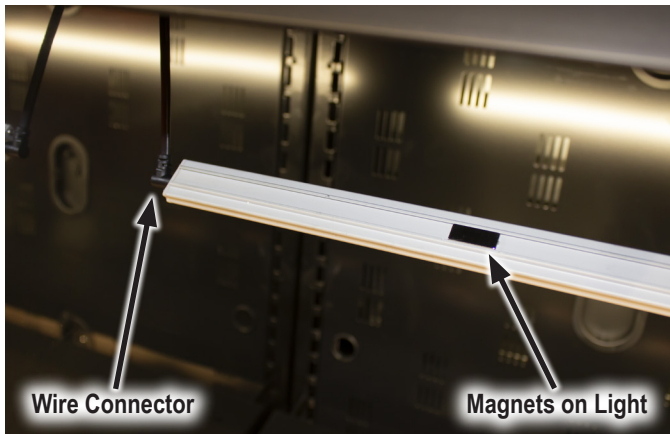
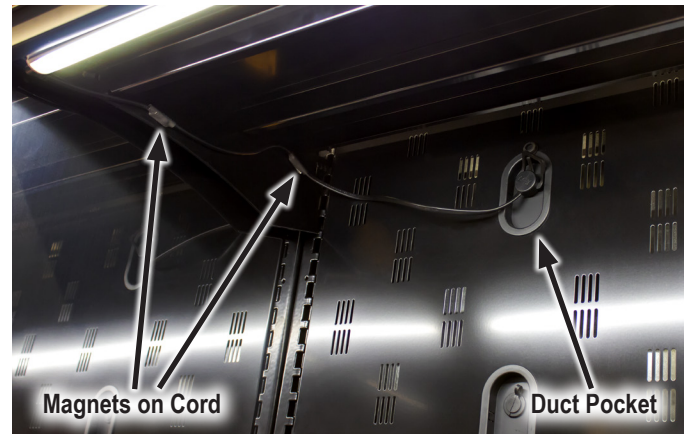

FIGURE 37: Plug Into the Nearest Duct Pocket



Canopy Lights

Canopy lights can be angled to provide the best lighting for the product. We recommend adjusting these while stocking the case.

Quick-Connect Spray Hose

A quick-connect spray hose is available for Reveal Merchandiser®. The quick-connect coupling is located in the return air grill behind the sill on the left end of the case (See Figure 33). The spray hose connects by pushing it into the coupling (See Figure 34).

At installation, water will need to be connected to either the 3/8" ID food grade hose or to the coupling itself (See Figure 35). To access the hose, the deck pans will need to be removed from the left end of the display case. The water line can enter the case through the bottom left of the rear wall of the display case, which is the same opening that refrigerant lines can run through (See Figure 38 on page 18 and Figure 39 on page 18).

FIGURE 33: Quick-Connect Coupling



FIGURE 34: Spray Hose Connected

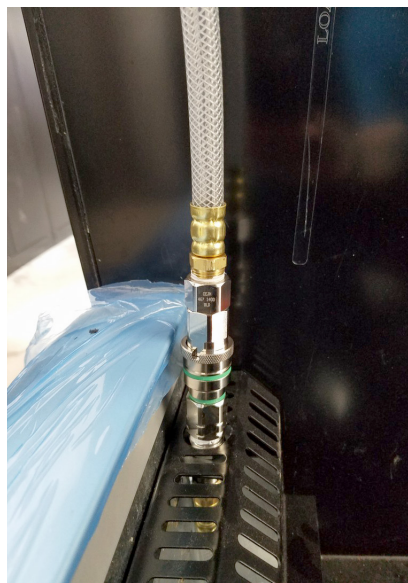
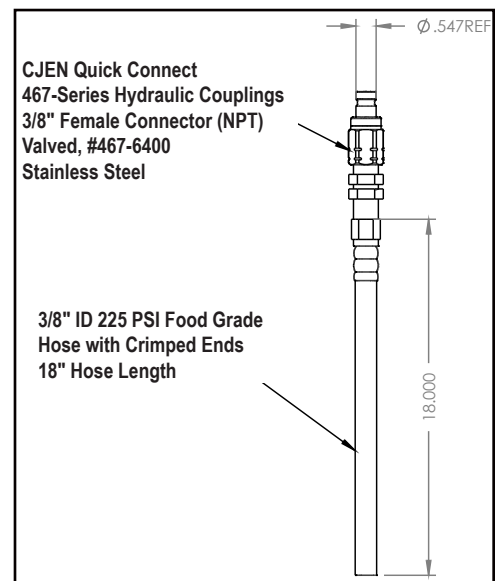

FIGURE 35: Connection Sizes



INSTALLATION & OPERATION

FIGURE 38: Rear Wall Opening for Water Lines (Exterior)

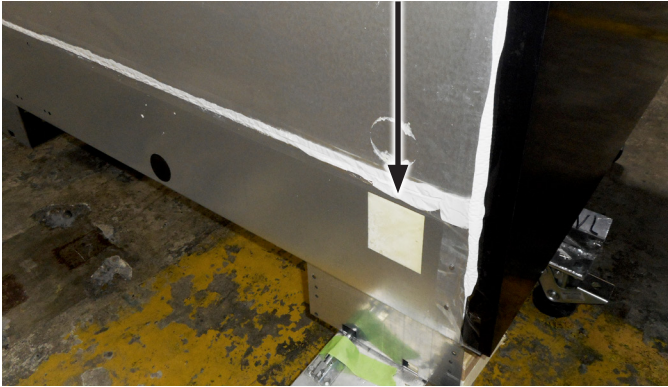
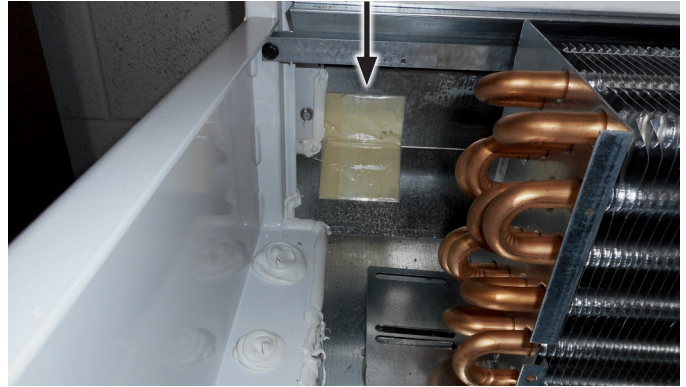

FIGURE 39: Rear Wall Opening for Water Lines (Interior)



Shelves & Stocking Product

Shelf location may be adjusted in 1" vertical increments in any position for best display advantage. Make sure the shelf brackets are securely seated before placing any product on the shelf. The standard shelves may be tilted down at a 10° angle. Optional shelf assemblies are available that may be tilted at 5°, 10°, or 15° angle. Bottom wire racks are available as either flat with front fence or adjustable with front fence, which can be set with a 15° angle.

The case may be stocked with product after it has operated at least 24 hours with correct case temperature and proper control operation. Peg hooks require airflow baffles above each set to maintain proper product temperatures. When stocking the shelves, leave a gap between the product and the shelf above, which allows an air curtain on top of the product. Angled, tiered, or lightly stocked shelves will reduce the air curtain and may require lower evaporator temps. Product should not extend beyond the front of the shelves or bottom wire rack. **Note: Do not place product on the return air grille or past the load limit line. Do not exceed shelf load capacity (See Figure 41 on page 19). Do not stand on the case when stocking or adjusting shelves.**

To unassemble a shelf, insert a putty knife between the side of the shelf and the shelf bracket. Pry the pieces apart to disengage the bracket.

Shelves can be ordered with 1", 2", or 3" acrylic product stops, which fit into aluminum price tag molding. Slide the product stop into the price tag molding and push it down to the bottom of the channel (See Figure 40). The channel of the price tag molding may need to be pried open with a screwdriver, but the product stop should slide in easily once started.

FIGURE 40: Acrylic Product Stops (1" Shown)



INSTALLATION & OPERATION

FIGURE 41: Shelf Load Capacities

SHELF TYPE	WIDTH	DEPTH	BRACKET TYPE	LOAD CAPACITY (LBS.)
Solid Shelf	36" 48"	10"	2-Position (0°/10°)	350/150
			4-Position (0°/5°/10°/15°)	350/250/150/100
		12"	2-Position (0°/10°)	350/150
			4-Position (0°/5°/10°/15°)	350/250/150/100
		14"	2-Position (0°/10°)	350/150
			4-Position (0°/5°/10°/15°)	350/250/150/100
		16"	2-Position (0°/10°)	350/150
			4-Position (0°/5°/10°/15°)	350/250/150/100
		18"	2-Position (0°/10°)	350/150
			4-Position (0°/5°/10°/15°)	350/250/150/100
		20"	2-Position (0°/10°)	350/150
			4-Position (0°/5°/10°/15°)	350/250/150/100
		22"	2-Position (0°/10°)	350/150
			4-Position (0°/5°/10°/15°)	350/250/150/100
		24"	2-Position (0°/10°)	350/150
			4-Position (0°/5°/10°/15°)	350/250/150/100
		27"	2-Position (0°/10°)	350/150

Note: 36" width only for 6' Reveal™ Cases

Adjustable Bottom Rack

The adjustable bottom rack includes the basket support bracket and rack.

1. Install the basket support bracket into the shelving slots at the desired height (See Figure 43).
2. Insert front rods of the angled rack into the correct slots on the return air grille (See Figure 42). *Note: the slots will not be level with the basket support bracket.*
3. Lower the hooks on the rear of the angled rack into the slots of the basket support bracket (See Figure 43).

FIGURE 42: Angled Rack Front Rods



FIGURE 43: Basket Support Bracket

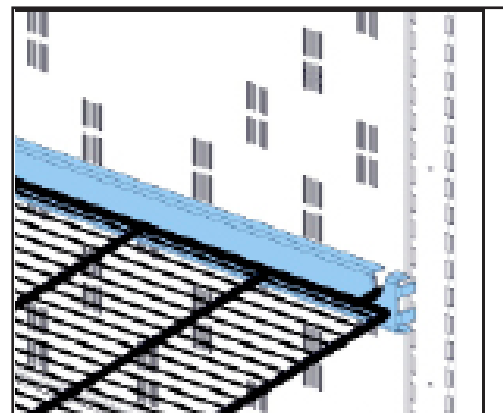

REFRIGERATION

⚠ WARNING! REFRIGERATION SYSTEMS USING R-744 (CO₂) ARE UNDER HIGH PRESSURE. DO NOT TAMPER WITH THE SYSTEM. CONTACT QUALIFIED SERVICE PERSONAL BEFORE DISPOSAL.

Symbols and Definitions



Symbol ISO 70000-1701 (2004-01)

Pressure

Mechanical Components

EVAPORATOR COIL & EXPANSION VALVE

The evaporator coil is located in the bottom of the case under the deck pans. The thermostatic expansion valve (TXV) is typically located at the end of the evaporator coil. The TXV is not preset, and superheat should be adjusted to 6-8°F. Contact Zero Zone for superheat setting if using high-glide refrigerants.

To adjust the TXV, remove the far right deck pan (See Figure 44). Remove the cap from the bottom of the TXV. When looking at the valve stem end, turn the valve stem counterclockwise to decrease superheat. Turn the valve stem clockwise to increase superheat. Measure the suction line temperature at the TXV sensing bulb and compare it to the suction temperature corresponding to the saturated pressure. Make sure that line pressure drop is taken into account. Turn the valve stem only 1/4 turn at a time and allow sufficient time (20 to 30 minutes) for the TXV to settle before making further adjustments. After the superheat has been adjusted, wipe the valve stem cap dry and screw it back on.

EVAPORATOR FANS

Air is circulated through the display case by fans, which are located below the deck pans in the bottom of the case (See Figure 45). Air is drawn through the front return air grill and discharged out of the honeycomb at the top. The fan motors must be operating at all times. Fan motors should be replaced with motors having the same characteristics including type, physical size, lubricant temperature range, wattage, and RPM. Fan blades should be replaced with OEM parts or have the same fan pitch as the OEM fan blade.

⚠ CAUTION! DISCONNECT POWER TO THE CASE BEFORE SERVICING ELECTRICAL COMPONENTS TO AVOID PERSONAL INJURY AND DAMAGE TO THE UNIT.

1. Disconnect power to the fan.
2. Remove the fan blade nut and fan blade.
3. Remove the mounting bolts and remove the fan assembly from the fan housing.
4. Remove the fan motor mounting screws from the back of the fan motor.
5. Replace the fan, and reverse steps 1-3 to install the cover. Restore case power.

FIGURE 44: Expansion Valve and Schrader Valve

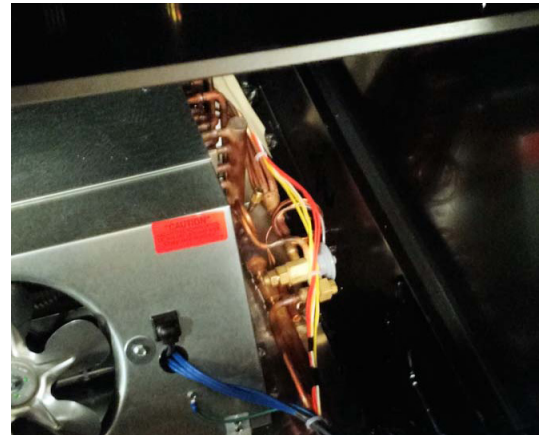

FIGURE 45: Fans and Case-to-Case Piping



REFRIGERATION

Refrigerant Piping

The display case must be connected to a refrigeration unit using the same refrigerant indicated on the display case serial tag.

Unless otherwise specified, the liquid and suction connections terminate inside the case under the coil cover. Refrigerant piping may enter the case through the left rear back panel or the left rear top panel of the case. Other exit options are available. The copper pipe should not touch or rub on the edges of the sheet metal.

Correct refrigeration line sizing and industry standard installation practices are essential for proper system operation. Zero Zone offers many refrigerant choices. We recommend using the Sporlan Virtual Engineer Toolbox to calculate sizing for liquid, suction, and discharge lines: <https://solutions.parker.com/sporlanvirtualengineer>. Go to the link, select the line type, and then enter the information required to calculate the recommended line size. Toggle between metric or imperial units as needed.

After connections have been made, the refrigeration access holes or penetrations in the case must be sealed completely with an aerosol-dispensed urethane insulation or equivalent (example: Great Stuff).

After all of the refrigeration piping and system components have been assembled, the entire system must be pressurized and checked for leaks. When the system is leak free, evacuate with a deep vacuum pump. Triple evacuation should be done to 500 microns or less, and nitrogen sweep is recommended. After the system has been thoroughly evacuated of all moisture and non-condensable gas, charge the system with the specified refrigerant.

Cases will be equipped with a liquid-line filter drier by default.

Glycol cases typically have a balance valve located in the outlet line inside of the case. If a stop solenoid is provided, it will also be located in the outlet line. Schrader valves are provided inside the case on the right-hand side of the coil for venting and draining the system.

Operation Set Points

Refer to the case spec sheet for btu/h requirements and electrical requirements. Operate the case at the proper settings to maintain product temperature of 41°F or below, per food safety regulations (**See Figure 46**). **Note: Set points based on flat shelves. Alternate shelving—such as angled or tiered shelving, peg hooks, or produce inserts—may require lower operating temperatures.**

FIGURE 46: Case Temperature Internal Control Options

SETTING	Meat			Beverage / Dairy / Deli / Produce		
Evaporator Temp	22°F			26°F		
Return Air Temperature Set Point	40°F			44°F		
Return Air Temperature Differential	4°F			4°F		
Discharge Air Temperature Set Point	27°F			31°F		
Discharge Air Temperature Differential	4°F			4°F		
SETTING	R-404A	R-448A	Sat. Temp	R-404A	R-448A	Sat. Temp
Condensing Unit Cut-In	62 psig	51 psig	25°F	67 psig	55 psig	28°F
Condensing Unit Cut-Out	54 psig	43 psig	19°F	59 psig	48 psig	23°F
Note: Set points based on superheat of 6-8°F. For high-glide refrigerants, use dew point for unit sizing. Adjust evaporator pressure as needed to maintain discharge air temperature. To receive the full benefit of high-glide refrigerant properties, the superheat may need to be lowered to 4-6°F. Contact Zero Zone with questions.						

REFRIGERATION

Case Thermometer

The cases are shipped with two thermometers. One thermometer is factory-mounted in the center ceiling pocket cover to sense the discharge air stream. The second thermometer is shipped loose and should be installed in the warmest product location as required by NSF. Specific field installation instructions are packaged with the thermometer that is shipped loose.

Off-Cycle Defrost

See Figure 47 for off-cycle defrost settings. During off-cycle defrost, refrigerant is stopped either by stopping the compressor or by closing the liquid line solenoid valve and allowing the compressor to pump down. The fans and lights remain on during off-cycle defrost.

If temperature termination is selected, set the termination temperature at 45°F for discharge air and coil temperature. **Note: Stocking or shopping during off-cycle defrost may cause premature defrost termination.**

FIGURE 47: Defrost Settings

SETTING	Meat	Beverage / Dairy / Deli / Produce
Defrost Type	Off-Cycle	Off-Cycle
Frequency	4 Per Day	4 Per Day
Duration	36 Minutes	30 Minutes

ELECTRICAL

General

Standard cases have 2 electrical circuits: the fan circuit and the lighting circuit (**See Figure 48**). *Always refer to the wiring diagram shipped with the case.*

CAUTION! A DISCONNECT NEEDS TO BE INCORPORATED IN THE FIXED WIRING.

FIGURE 48: Sample Wiring Diagram

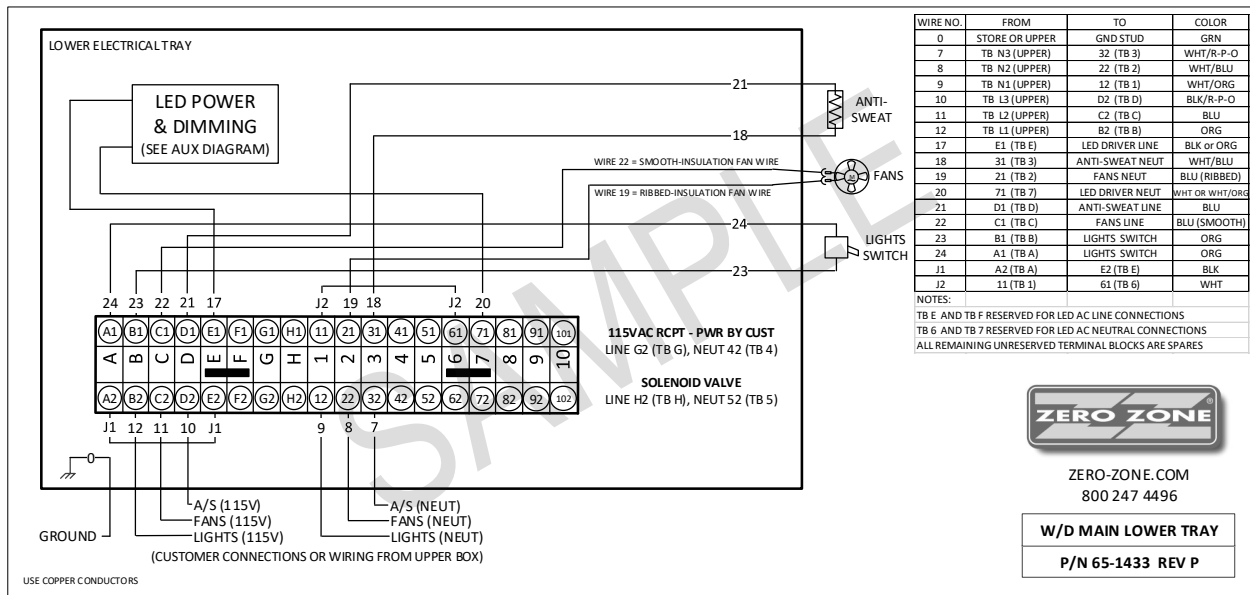

The case light switch is located on the right side of the interior ceiling (**See Figure 49**).

The electrical enclosure is located behind the lower trim on the right side of the case (**See Figure 50**). The electrical raceway allows for simple case-to-case wiring (**See Figure 51**). Power can be supplied to the case through the access hole under the electrical enclosure (**See Figure 52**). The enclosure includes the power connection and power supplies for the LED light bars. Terminal blocks are provided for supplying power for fans and lights. A ground connection can also be made inside the electrical enclosure.

Optional top electrical will be located in a junction box on top of the case.

FIGURE 49: Light Switch



FIGURE 50: Bottom Electrical Enclosure

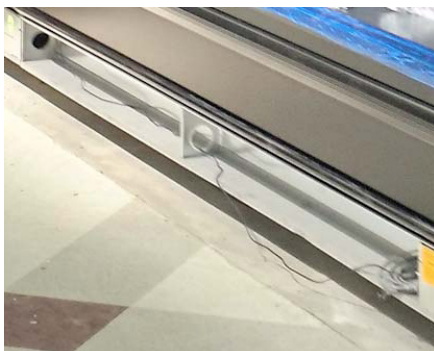

FIGURE 51: Case-to-Case Wiring



FIGURE 52: Electrical Supply Access Hole



ELECTRICAL

External wiring should be sized according to the amperage rating stamped on the serial tag, which is located on the ceiling inside the left-hand door. Typical electrical values are shown on specification sheets that are available online. All internal wiring has been completed at the factory.

All wiring must comply with the National Electrical Code (NEC) and all local codes. After installing the equipment, correct operation of the electrical circuits, controls, and defrost controls should be verified. All operating voltages and amperages should be measured and recorded. Display cases that do not include a remote disconnect must be field installed with a remote disconnect in accordance with NFPA 7.0 of the National Electric Code.

Controller Sensor Wires

The factory-installed temperature probe (discharge air) is located in the false ceiling. Temperature probe wires are white (common) and green (supply).

MAINTENANCE

Cleaning

Although each Zero Zone display case is thoroughly cleaned before shipping, the cases should be thoroughly cleaned again before start-up and routinely thereafter to maintain a clean appearance. With just a few minutes of cleaning each week, the case will remain in top condition.

1. Do not use high-pressure water or steam to clean the interior or any components.
2. Do not wash fan motors. A damp cloth can be used to wipe the fan motors. Cover the fan motors with a plastic bag when washing the case.
3. Wipe out the case interior using mild detergent and warm water (never an abrasive cleaner).
4. Clean windowed ends and mirrors using glass cleaner. Cleaning interior glass reduces fogging and increases visibility. Do not use any cleaning products containing silicon for anti-fog.
5. Internal components can be cleaned after removing coil covers, access panels, and sheet metal components. Use a mild detergent and warm water or a mild sanitizer.
6. If the case is equipped with a condensate pan and pump, the drain should be blocked before washing coils. Water can be removed with a shop vacuum.
7. Coils may be cleaned with a garden hose or pails of water. If the case is equipped with a condensate pan and pump, cases should be cleaned with a minimal amount of water so the evaporator, pump, and drain pans do not get overfilled.
8. The case drain should frequently be cleaned of debris to prevent clogging. If water is rising, check if the drain is clogged.

UNDER CASE FLOOR CLEANING (NSF)

The floor under your Zero Zone display case can be cleaned by following these steps:

1. Remove the fasteners attaching the kickplate to the case. The fasteners are accessed from the front of the unit.
2. With the kickplates removed, vacuum under the case to remove any dirt, debris, and dust build-up.
3. Mop under the unit using non-abrasive floor cleaner and warm water.
4. When finished mopping, squeegee any remaining water under the unit to the floor drains to speed up the drying process. Replace the kickplates when the floor has dried.



For other technical support, please refer to
the Technical Resources page at:

WWW.ZERO-ZONE.COM

or contact the Zero Zone Service Department at:

800-247-4496

All specifications subject to change without notice.

