

REVEAL

merchandiser®



ZERO ZONE

REVEAL MERCHANDISER® MULTI-DECKS WITH DOORS

With CoolView® Ultra™ Doors & ChillBrite® LED Lighting

INSTALLATION & OPERATION MANUAL



66-0109 REV I • MAR 2026



Table Of Contents

ZERO ZONE WARRANTY	1
INTRODUCTION	2
INSTALLATION & OPERATION	4
■ Delivery Inspection.....	4
■ Packaging.....	4
■ Location.....	4
■ Moving Cases.....	5
■ Optional Bases.....	5
■ Leveling.....	6
■ Lineup Assembly.....	8
■ Case Joint Caulking (Butyl*).....	9
■ NSF Compliance Sealing (Silicone).....	10
■ Reveal to Reveal with Doors Joint Instructions.....	11
■ Door Leveling (Door Sag/Sawtooth).....	12
■ Bottom Mounting Plate.....	12
■ Top Mounting Plate.....	12
■ Drain.....	12
■ Kickplates.....	13
■ Bumper.....	13
■ Top Trim.....	13
■ CoolView® Doors.....	13
■ CoolArc™ Door Handles.....	13
■ Door Closer / Adjusting Door Tension.....	14
■ Hold-Open Bracket.....	14
■ Door Gasket.....	14
■ Installing a Door.....	14
■ Removing a Door.....	15
■ Shelves & Stocking Product.....	15
REFRIGERATION	16
■ Mechanical Components.....	16
■ Refrigerant Piping.....	16
■ Operation Set Points.....	17
■ Off-Cycle Defrost.....	17
■ Case Thermometer.....	17
ELECTRICAL	18
■ General.....	18
MAINTENANCE	19
■ Cleaning.....	19
■ Under Case Floor Cleaning (NSF).....	19

When installing a Reveal Merchandiser® with Doors in a Hybrid™ configuration, refer to both this manual and the Hybrid™ Installation & Operation Manual.

ZERO ZONE WARRANTY

Limited Warranty

Zero Zone, Inc. (Seller) hereby warrants that any products manufactured by it and sold are warranted to be free from defects in material and workmanship, under normal use and service for its intended purpose, for a period of one (1) year from the date of original installation (not to exceed 15 months from the date of factory shipment). Zero Zone ChillBrite® LED Lighting carries a 5-year parts warranty. Zero Zone CoolView® Doors carry a 10-year glass pack parts warranty. The obligation under this warranty shall be limited to repairing or exchanging any part, or parts, FOB Factory, which is proven to the satisfaction of the Zero Zone Service Department to be defective. Zero Zone reserves the right to inspect the job site, installation, and reason for failure. This limited warranty does not cover labor, freight, or loss of food or product, including refrigerant loss. This warranty does not apply to motors, switches, controls, lamps, driers, fuses, or other parts manufactured by others and purchased by the Seller unless the manufacturer of these items warrants the same to the Seller, and then only to the extent of those manufacturer's warranty to the Seller. Any products sold on an "AS IS" basis shall not be covered by this warranty.

Extended Warranties

In addition to the standard limited warranty, for further consideration, the Seller will extend to the original purchaser prior to shipment, a limited extended warranty on the compressor only, following expiration of the standard warranty. The Seller agrees to repair or exchange, at its option, or provide reimbursement for such exchange as directed, less any credit allowed for return of the original compressor, of a compressor of like or similar design and capacity, if it is shown to the satisfaction of Zero Zone that the compressor is inoperative due to defects in factory workmanship or material under normal use and services as outlined by Zero Zone in its Installation & Operation Manuals and other instructions.

Length of Extended Warranty

Any compressor warranty may be extended for an additional four (4) years, but such extension must be purchased prior to shipment to be effective. This warranty is only for the compressor and not for any other associated parts of the refrigeration system.

Product Not Manufactured by the Seller

The written warranty, if any, provided by the manufacturer of any part of the refrigeration unit sold by Seller to Buyer, but not manufactured by Seller, is hereby assigned to the Buyer. However, Seller makes no representation or warranty regarding the existence, validity, or enforceability of any such written warranty.

Limitation and Exclusion of Warranties

THE WARRANTIES SET FORTH HEREIN ARE EXCLUSIVE AND IN LIEU OF ALL OTHER WARRANTIES AND REMEDIES WHATSOEVER, INCLUDING, BUT NOT LIMITED TO, IMPLIED WARRANTIES OF MERCHANTABILITY AND/OR FITNESS FOR A PARTICULAR PURPOSE.

INTRODUCTION

Important User Information

Copyright © 2026 Zero Zone, Inc.

All rights reserved. No part of the contents of this manual may be reproduced, copied, or transmitted in any form or by any means including graphic, electronic, or mechanical methods or photocopying, recording, or information storage and retrieval systems without the written permission of the publisher, Zero Zone, unless it is for the purchaser's personal use.

The information in this manual is subject to change without notice and does not represent a commitment on the part of Zero Zone. Zero Zone does not assume any responsibility for any errors that may appear in this manual. In no event will Zero Zone be liable for technical or editorial omissions made herein, nor for direct, indirect, special, incidental, or consequential damages resulting from the use or defect of this manual.

The information in this document is not intended to cover all possible conditions and situations that might occur. The end user must exercise caution and common sense when installing, using, or maintaining Zero Zone products. Zero Zone products should only be installed by qualified, professional refrigeration technicians. If any questions or problems arise, call Zero Zone at 800-247-4496.

Any change to a Zero Zone product made during the installation, start-up, or at any other time must be submitted in writing to Zero Zone for approval and be approved by Zero Zone in writing prior to commission. The product warranty is voided when any unapproved change is made to a Zero Zone product.

Manufacturer

Zero Zone, Inc.

110 N Oakridge Dr • North Prairie, WI 53153 • 800-247-4496 • www.zero-zone.com

Intended Use

Zero Zone products are intended to be installed and used as described in this manual and other related Zero Zone literature, specifications, drawings, and data. All Zero Zone products must be leveled after being installed.

This appliance is not intended for use by persons (including children) with reduced physical, sensory, or mental capabilities, or lack of experience and knowledge, unless they have been given supervision or instruction concerning use of the appliance by a person responsible for their safety. Children should be supervised to ensure that they do not play with the appliance.

Do not store explosive substances such as aerosol cans with a flammable propellant in this appliance.

Testing Standards

These display cases were designed and tested using the following industry standards:

- NSF 7 – Commercial Refrigerators and Freezers (ANSI Approved) (equipment certified by NSF)
- NSF 51 – Food Equipment Materials (ANSI Approved) (equipment certified by NSF)
- UL 471 – Commercial Refrigerators and Freezers (ANSI Approved) (equipment certified by ETL)
- ASHRAE Standard 72 – Method of Testing Commercial Refrigerators and Freezers (ANSI Approved)
- AHRI 1200 – Performance Rating of Commercial Refrigerated Display Merchandisers and Storage Cabinets (ANSI Approved)
- DOE Compliant (All U.S. Sales and U.S. Territories)

ASHRAE Standard 72 specifies the test conditions for the equipment. It includes the ambient conditions of 75°F dry bulb and 55% RH. It also specifies the door opening requirements for the performance test. Doors are opened six times in one hour for six seconds. The door opening test period is for eight hours during one 24-hour performance test. As an example, a 5-door case will have 240 door openings during one 24-hour test. Consult the factory if your store exceeds these test conditions.

INTRODUCTION

Display Case Models

The information contained in this manual pertains to the following Zero Zone display cases:

CASE MODEL	DESCRIPTION	DOOR SIZE & TYPE
ORMC83D	83" Standard Multi-Deck with Doors	24" x 69" CoolView® Ultra™ French Doors
ORMC88D	88" Tall Multi-Deck with Doors	24" x 74" CoolView® Ultra™ French Doors

Case Features

Zero Zone produces high quality refrigerated display cases using state-of-the-art components, including a high efficiency evaporator coil. Case features may include:

- Electronic fan motors
- Zero Zone ChillBrite® LED Lighting
- Zero Zone CoolView® Ultra™ Doors
- 90-bar rating available for CO₂ display cases

INSTALLATION & OPERATION



CAUTION!

DO NOT STAND ON TOP OF A REVEAL MERCHANDISER® WITH DOORS. THE TOP OF THE CASE IS NOT DESIGNED TO SUPPORT THE WEIGHT OF A PERSON.

Delivery Inspection

Zero Zone display cases are carefully factory-tested, inspected, and packed to ensure delivery in the best possible condition. The equipment should be unwrapped and checked for damage **immediately** upon delivery. **DAMAGE MUST BE NOTED AT TIME OF DELIVERY, AND ALL CLAIMS FOR DAMAGES MUST BE FILED WITH THE TRANSPORTATION COMPANY, NOT WITH ZERO ZONE.** The carrier will supply necessary report and claim forms. Contact your Zero Zone sales representative or the service department to arrange for replacement parts.

Do not leave, store, or hold case outdoors in direct sunlight or high ambient temperature. With the end panels on, the case is airtight; the inside temperature of the case will increase, and the heat will be unable to escape. This could potentially cause any plastic inside the case to deform or warp.

Note: The installation of the appliance and the refrigerant unit must only be made by the manufacturer's service personnel or suitably qualified person.

Packaging

Each **case** in a lineup is labeled to identify the **lineup** and **joint**. The label uses a two digit number designation, separated by a decimal. The first number indicates the case lineup. The second number indicates the case joint. Case joints begin with the number "1" at the left-most joint in the lineup when looking at the front of the lineup. The first case in the lineup will be labeled on the right end and the second case in the lineup will be labeled on the left end. The numbers on each end to be joined will match (**See Figure 1**).

FIGURE 1: Case Label Information

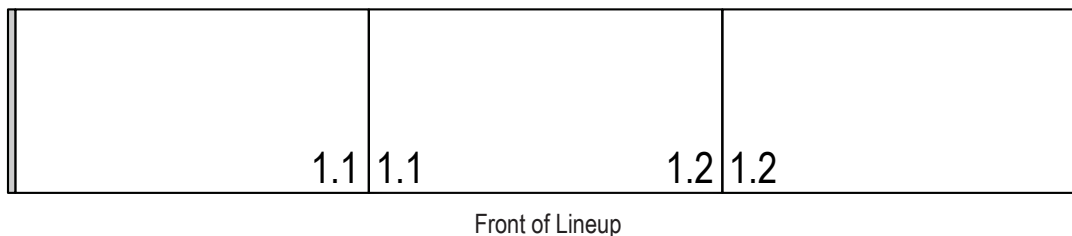

The *first* case in a lineup (with the right side labeled "x.1") has a packet attached to the shelving that contains touch-up paint. *Every* case in a lineup has a packet attached to the shelving that contains important information about the case and/or lineup and, if applicable, special instructions for installing ordered options.

Bumpers and kickplates are shipped on top of the case. Shelves for the case are tie-wrapped and blocked into the individual cases. Other accessories like drain traps, drain pans, and condensate evaporation pans are shipped in the cases that require the parts.

Materials for joining cases—including caulk, joining bolts, splices, and end filler posts—are shipped in each case to be joined.

The doors are prevented from opening during shipment with the use of door-holding shipping brackets. The brackets are screwed to the top of the case at each door and should be removed when the case is unpacked.

Location

Zero Zone cases must not be installed in the direct rays of the sun or near a source of radiant heat. Be certain that the floor under the installation is of sufficient strength to prevent sagging. Uneven surfaces will result in reduced performance.

Cases should be set to allow a minimum 3" of space behind the back of the units. This will allow necessary air to circulate behind the display cases and prevent condensation. Higher humidity stores with minimal air circulation require at least a 4" gap. A minimum 2" gap is recommended between cases on end-to-end installations. All minimum spacing requirements may increase if seismic restraints are used.

Building soffits must be set back at least 6" from the front of the case to allow access to electrical wiring on the top of the case.

INSTALLATION & OPERATION

Moving Cases

Various tools and equipment may be used to move cases including, but not limited to, a forklift, a Johnson bar, a pallet jack, furniture rollers, casters, or a Rol-A-Lift. Be careful to avoid damaging the store flooring. Only certified forklift drivers should use forklifts to move the cases. The case should only be lifted off the floor as high as necessary for transport. The forklift should be driven slowly; avoid abrupt motions or bumps.

- Use the end frame to push/pull the case. For best results, push/pull lower on the end frame. **Do not push/pull on the mullions as this can cause the mullions to bend.**
- When using a Johnson bar, only contact the sheet metal of the bottom foamed panel. **Do not contact the bumper support. Be careful not to pierce the sheet metal with the corner of the Johnson bar.**
- When using a pallet jack or furniture rollers, only place them under the floor panels. **Do not place them under the bumper support or drain pipe as that will crush the components.**
- Cases have steel protective support plates under the end panels (not under insulated dividers) to protect them from Johnson bar damage.

Make sure that a forklift with the proper fork dimensions is available. **Forks must be 48" long, 1 1/2" to 1 3/4" thick, and no more than 4" wide to fit the bases.** Refer to the table below for instructions.

CASE MODEL	INSTRUCTIONS
4ORMCD (2-Door)	Forks must extend 20" to 24" under the case from either end
6ORMCD (3-Door)	Forks must extend 26" to 30" under the case from either end
8ORMCD (4-Door)	Forks must extend 39" to 43" under the case from either end
12ORMCD (6-Door)	Forks must extend 44" to 47" under the case from either end

OPTIONAL BASES

For low shipping height applications, such as 80" tall doorways, Zero Zone offers 1" bases or 1 3/4" bases.

- Cases with 1" bases will be shipped on a wooden pallet and are not forkliftable. The case can be removed from the pallet to slide it through the 80" doorway.
- The 1 3/4" bases are expandable to accommodate up to 1 3/4" thick forks (See Figure 2). To use a forklift on the expandable bases, raise the case with a Johnson bar and place wooden blocks under the case, allowing the base to expand enough for forks to be inserted.

Cases with 1" or 1 3/4" bases will be set into nested bases (See Figure 3). The drain elbow will be shipped loose and must be installed using extra thick PVC cement after the case set in place.

Spacer blocks (also called filler blocks) are included in the end bases of 4 and 6-door cases that use bases which are 4 1/2" or taller. These blocks limit the case's forward tilt while it is being lifted by a forklift. The forks should be inserted above the spacer blocks (See Figure 4).

FIGURE 2: Expandable Base

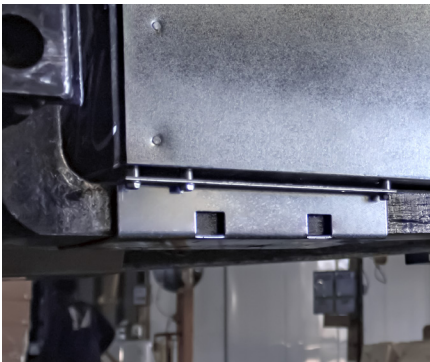

FIGURE 3: Nested Base

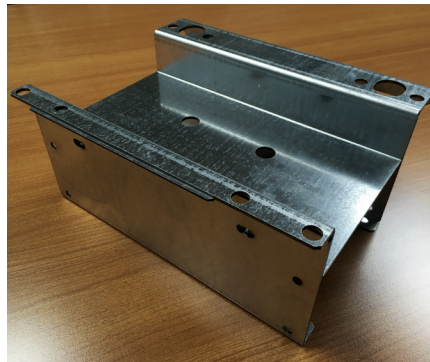
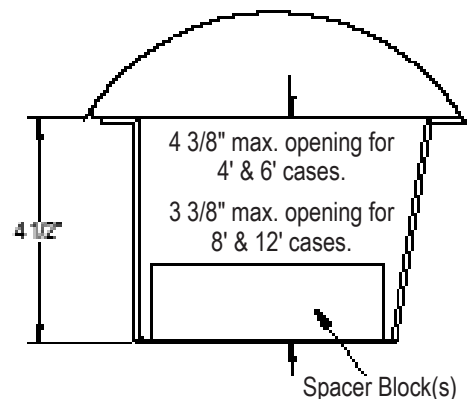

FIGURE 4: Spacer Block



INSTALLATION & OPERATION

Leveling

Cases should be set level right to left to allow complete drainage of defrost and condensate water. Since a level floor area is seldom available, the following steps are recommended to ensure a level installation. If your case uses seismic restraints, specific instructions for attaching seismic restraints are included in your document package. Read and understand these instructions before assembling the lineup.

1. Measure off and mark on the floor the exact dimensions of the case lineup (**See Figure 5**). Refer to the fixture plan or floor plan.
2. Snap a chalk line at the locations for the front and back positions of the bases.
3. Mark locations of all joints, both front and back.
4. Using a laser level or transit, find the highest point along both base position lines. Using the high point as a reference, mark the difference directly on the floor to each base, both front and back (**See Figure 6**).

FIGURE 5: Measure and Mark Exact Case Outline



FIGURE 6: Mark Floor Level Difference

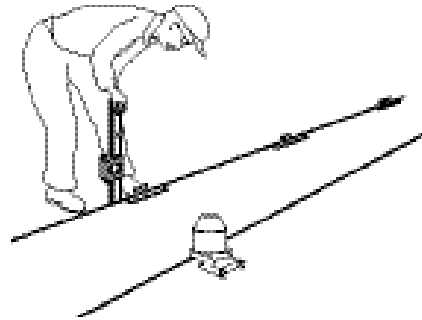

5. Place enough shims under each base to equal the highest point. Shims should not extend beyond the front case bases or they will interfere with installing trim. The shims should be oriented to sit under the front and rear bends of each base. Tape all shims in place (**See Figure 7**). After the case is set, additional shims may need to be added at specific base locations (**See Figure 9 on page 7**).

FIGURE 7: Tape Shims on the Floor Under Each Base

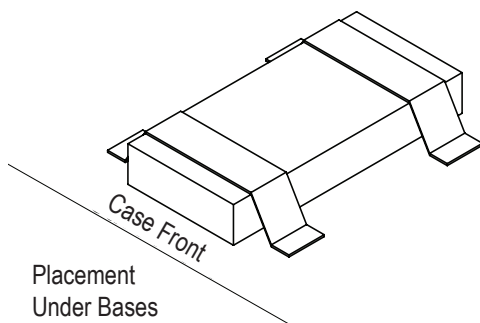
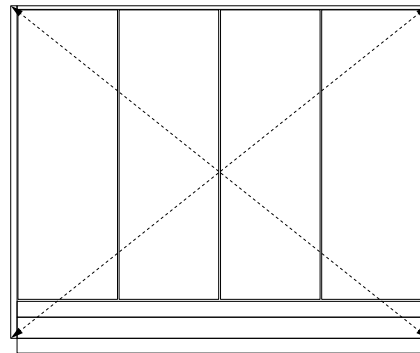

FIGURE 8: Case Squareness



6. The case must be leveled front-to-back and side-to-side. Ensure that the case is set square to within 1/8". Measure squareness from top right corner to the bottom left corner, and then again from the top left corner to the bottom right corner. Measurements should be equal. Difference should be no more than 1/8" (**See Figure 8**).
7. Cases should be set with a slight backward tilt to offset the forward lean of a fully loaded case. We recommend an additional 3/8" of shims be installed under the front bases after the case is leveled.
8. Place additional support shims under any bases with gaps taller than one shim. **Note: Total height of shims should be less than 3/4".**

INSTALLATION & OPERATION

FIGURE 9: Reveal Merchandiser® Base Locations

Drawings are top views with bases shown under the case. The front of the case is toward the bottom of the page.
Case length does not include end panels (1 1/2" wide each).

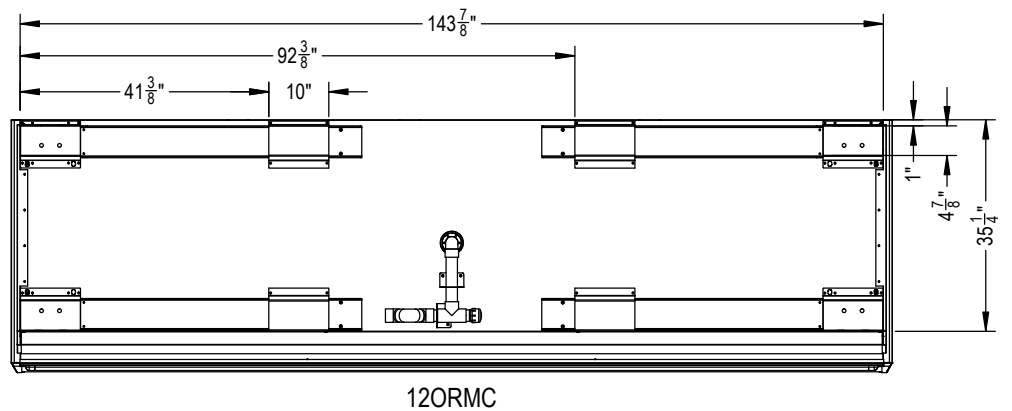
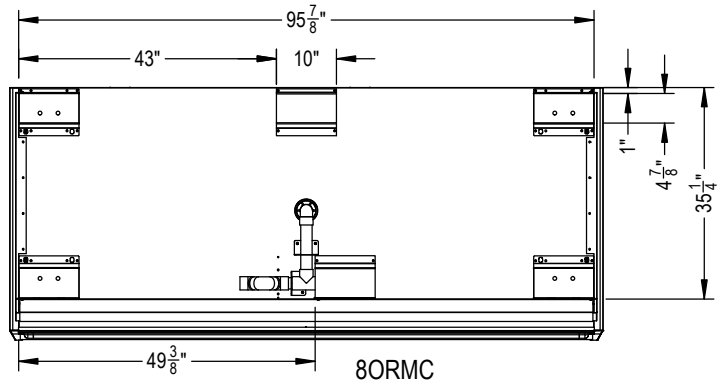
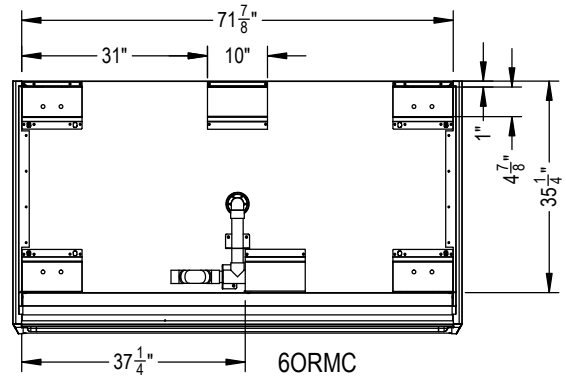
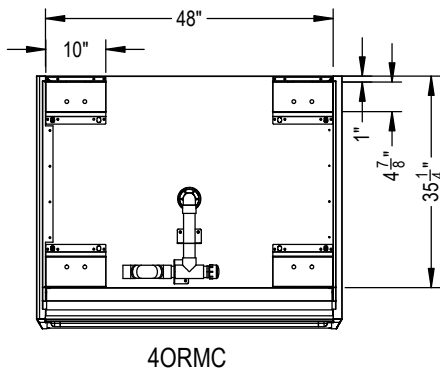

INSTALLATION & OPERATION

Lineup Assembly

Zero Zone display cases have been designed for continuous display so that multiple cases may be joined together to create a lineup of any desired length. The lineup will be ready for assembly after removing the packaging material.

A case lineup must be properly aligned, which starts with properly leveling the case ([See "Leveling" on page 6](#)). It is crucial to use a laser level to measure the high points in the floor and properly shim each base location.

The bottom of the end panels are protected by steel support plates, which must be unbolted and removed before the lineup is set. There are bolts that go up through the support plates into the underside of the foamed floor.

A case must be prepared with Butyl caulk before setting the next case in the lineup. Case caulking instructions and caulk are shipped with every case ([See Figure 11 on page 9](#)).

Move the next case into position within 1/4" of the first case. Align the joining holes using a drift pin or screwdriver through the joining holes. Bolt the cases together using the provided joining hardware—4 hex bolts, 4 hex nuts, 8 washers, and 1 rubber grommet ([See Figure 10](#)). Begin tightening the bolts at the top rear, working down the back of the case and up the front, making sure that the seams are flush. **Do not pull cases together using joining bolts.** Install the rubber grommet in the electrical enclosure pass-through hole at the joint.

The interior case seams must be sealed using silicone sealant for NSF compliance ([See Figure 12 on page 10](#)). Do not allow Butyl caulk and silicone sealant to contact one another as this may affect adhesion or color of each.

FIGURE 10: Case Joining Hardware

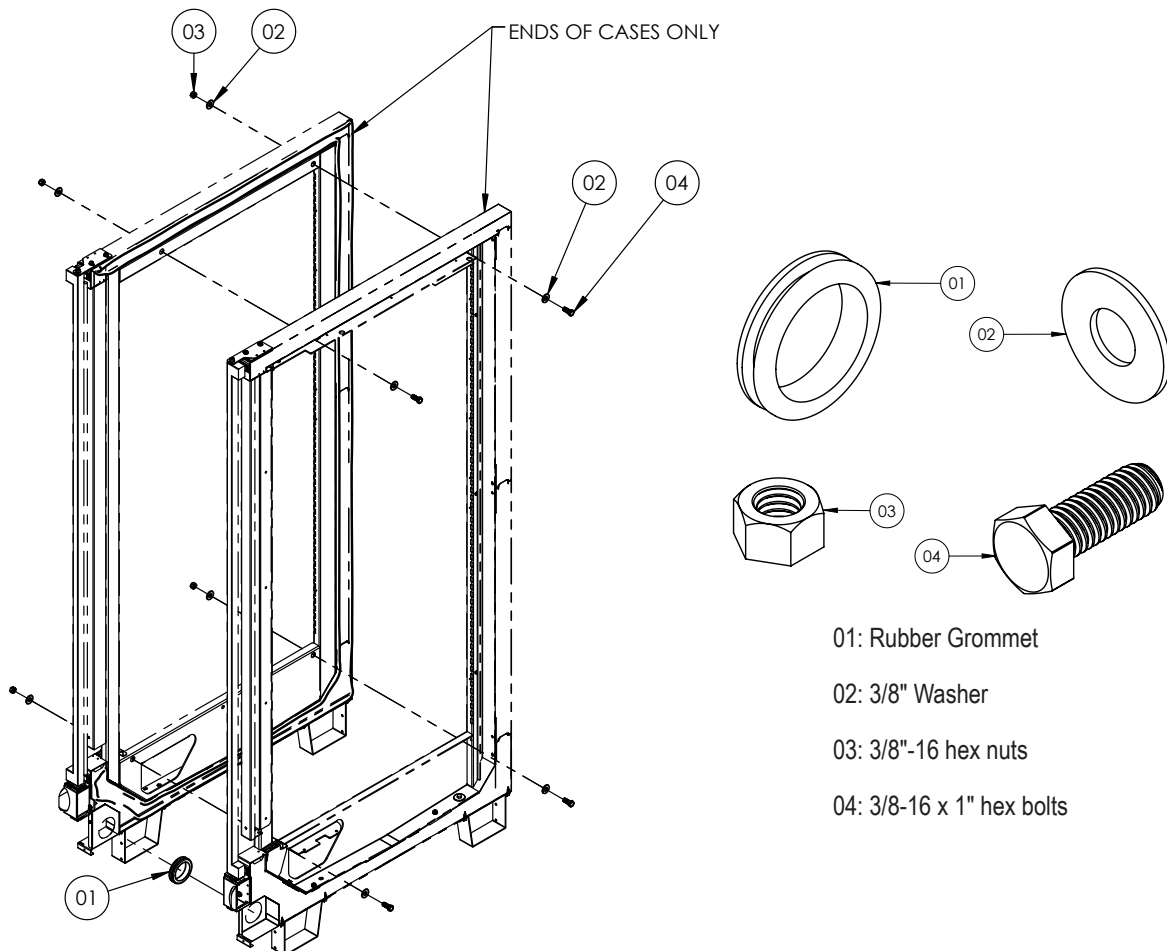

INSTALLATION & OPERATION

Before joining the cases, remove all packaging material on the display case, including any spacer blocks inside the bases. Repeat caulking between each case in the lineup.

FIGURE 11: Case Joint Caulking (Butyl*)

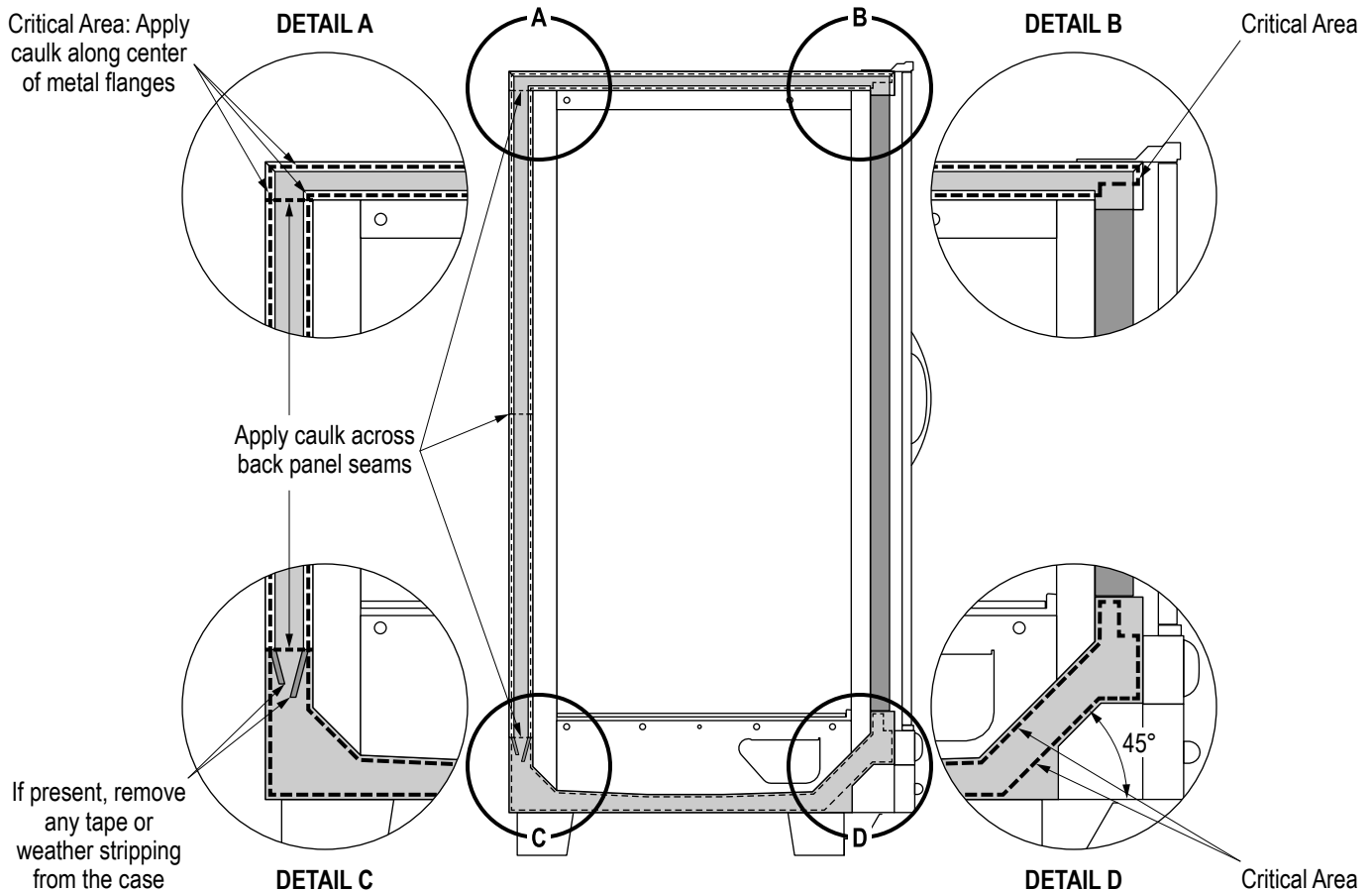

IT IS CRITICAL TO FOLLOW THIS PROCEDURE TO ENSURE CASES ARE PROPERLY SEALED.

SURFACES TO BE CAULKED MUST BE CLEAN, DRY, FREE OF TAPE/ADHESIVE, AND FREE OF FROST (ABOVE 40°F).

Note: Apply Butyl caulk to only one case—not both cases. The caulk will spread out when the cases are pushed together, and excessive caulk may squeeze out of the joint. Wipe away any caulk that squeezes out. Butyl caulk will not mix with silicone sealant (used for NSF sealing), which will affect adhesion of both.

1. Apply 1/2" thick beads of Butyl caulk* along the ceiling, rear wall, and the bottom of the case where indicated by the dashed lines in the drawing. Caulk must be continuous with no gaps. Always apply 2 beads where specified.
2. After cases are joined and tightened, caulk the top and back exterior seams, if accessible, to ensure a tight seal.
3. **See Figure 12 on page 10** for information about NSF compliance sealing with silicone sealant.

*DO NOT APPLY BUTYL CAULK ON SEAFOOD OR BAKERY CASES. Butyl caulk never cures and emits vapors that affect seafood and bakery products. Recommended alternative caulk: Polyurethane-based (full curing, durable, moisture-activated) or silicone-based (full curing).

INSTALLATION & OPERATION

FIGURE 12: NSF Compliance Sealing (Silicone)

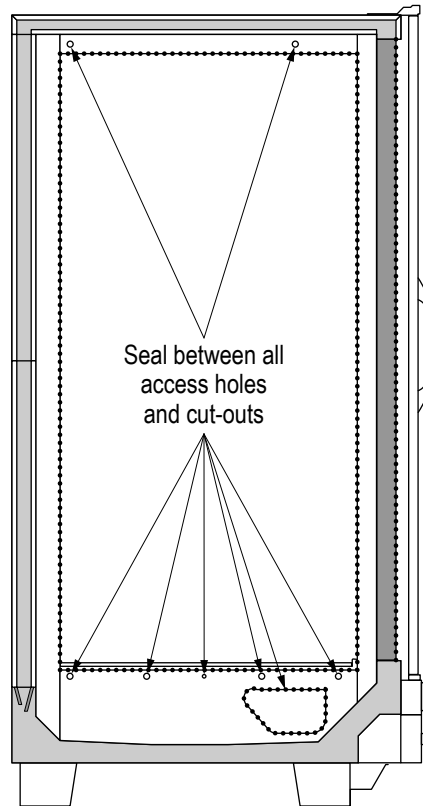

THIS PROCEDURE MUST BE FOLLOWED FOR NSF COMPLIANCE.

SURFACES TO BE SEALED MUST BE CLEAN, DRY, FREE OF BUTYL CAULK, AND FREE OF FROST (ABOVE 40°F).

Note: Cases must be properly caulked and joined before NSF sealing. Wipe away any Butyl caulk that squeezes out of the case joint. Butyl caulk and silicone sealant will not mix, which affects the adhesion of both. See Figure 11 on page 9.

1. Apply silicone-based sealant in small, continuous beads where indicated by the dotted lines in the drawing. Do not thin or feather, as that will affect adhesion.
2. Sealant must be added between cases at case joints, between a case and an end panel, and between all access holes and cut-outs in the case end frame.

INSTALLATION & OPERATION

Reveal to Reveal with Doors Joint Instructions

CAUTION! THE INSULATED DIVIDER PANEL IS SHIPPED INSTALLED ON THE REVEAL WITH DOORS CASE. DO NOT REMOVE ALL (3) BOLTS NOTED IN FIGURE 13 AT THE SAME TIME! AT ALL TIMES, AT LEAST TWO BOLTS (THROUGH OR SHORT) MUST BE THROUGH THE CASE END FRAME AND INTO THE PANEL TO PREVENT THE PANEL FROM SHIFTING OUT OF POSITION.

Note: The images shown provide reference for the Reveal (open) display case being installed to the left of the Reveal with Doors display case when viewing from the front. The view will be opposite for Reveal (open) display case to be installed to the right of the Reveal with Doors display case.

1. Remove a joint mounting bolt and washer from one location shown in **See Figure 13** and drill a 5/16" hole through the insulated divider panel from outside the Reveal (open) display case.
2. From inside the Reveal with Doors display case, push the removed bolt through its original hole in the end frame and into the hole drilled in step 1.
3. Repeat steps 1 and 2 for the remaining two bolts, then proceed to step 4.
4. After the Reveal with Doors display case is set, remove the bolts reinserted per step 2 by pushing the supplied through bolts (with washers) into the drilled holes from inside the Reveal (open) display case one at a time (**See Figure 15**). Inside the Reveal with Doors display case, install nuts and washers on all (3) through bolts and torque the nuts to 60 lbs-in. Washers **must** be used under each bolt head and under each nut.
5. From inside the Reveal (open) display case, install short (removed) bolts and washers in the locations indicated in **Figure 14**. Washers **must** be used under each bolt head. Torque the bolts to 60 lbs-in.

FIGURE 13: Drill Locations

View of left end from inside Reveal with Doors display case

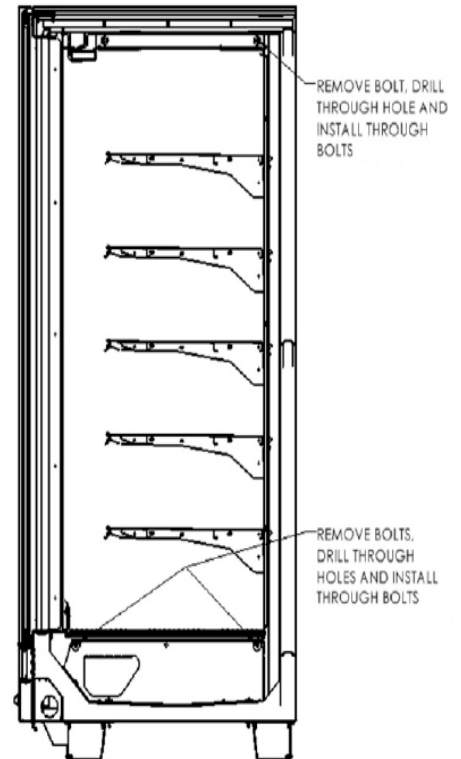

FIGURE 14: Short Bolt Installation

View of right end from inside Reveal with Doors display case

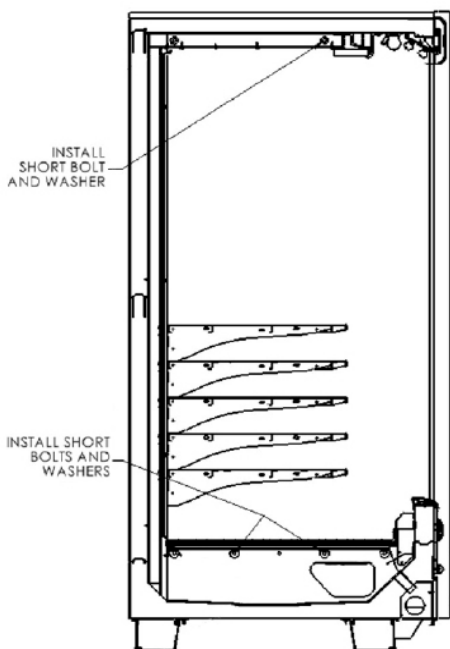
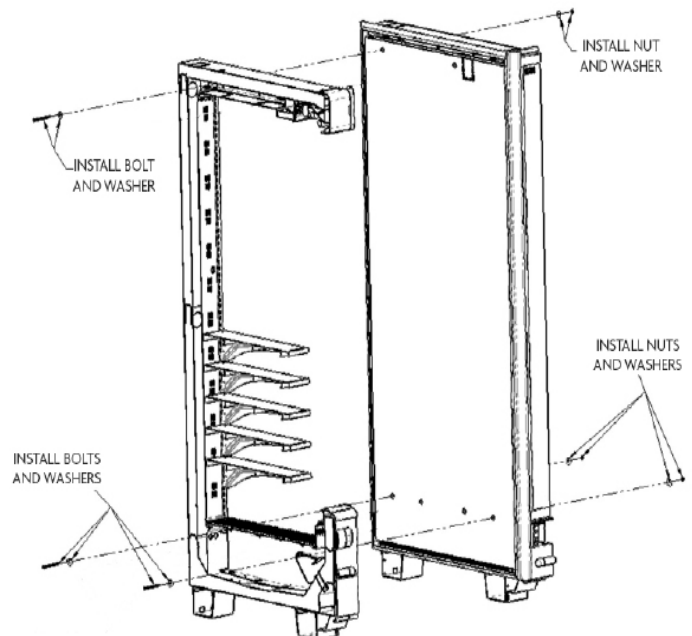

FIGURE 15: Through Bolt Locations

Exploded view of right end of Reveal display case



INSTALLATION & OPERATION

Door Leveling (Door Sag/Sawtooth)

Doors must be leveled before the bumper and kickplate are installed (See Figure 16).

For French-swing doors, there should be a 7/16" gap between doors at the handle side and a 3/8" at the hinge side. To set the proper gaps, loosen the screws holding the top or bottom door mounting plates, then shift the door.

BOTTOM MOUNTING PLATE

To move the bottom mounting plate, the center locking screw (located behind the bumper) must be loosened.

1. To remove the bumper, use a flathead screwdriver to pry it up from the bottom. Lift the edge, and then slide the screwdriver down the entire length of the bumper to loosen it. Once the bottom edge is disconnected, use a hammer to tap the screwdriver upwards and disengage the bumper from the upper track. Remove the bumper.
2. Loosen the center locking screw by 2 turns, accessed through the hole in the bumper support plate (See Figure 17). This will allow the bottom mounting plate to shift. **Do not remove the center locking screw.**
3. Tap the door's aluminum extrusion with a rubber mallet to shift the door. Once the door is in position, retighten the center locking screw.

TOP MOUNTING PLATE

The top mounting plate is located on top of the case behind the top trim.

1. Loosen all 3 screws that secure the slotted plate by 2 turns (See Figure 18). **Do not remove the screws.**
2. Tap the door's aluminum extrusion with a rubber mallet to shift the door. Once the door is in position, retighten all screws.

Drain

The 1.5" PVC drain line exits from the bottom center of the case. The lateral runs of drain pipe should be installed through the bases, as needed (See Figure 19). There is no room in front of the base for the drain pipe because the kickplate installs directly to the front of the bases.

Install the drain tee to the outlet pipe and a drain trap to the tee. Plug the open end of the tee using the clean-out plug supplied with the drain trap kit. The drain line must be pitched away from the case. The tee, drain trap, and plug are supplied with the case. The drain trap must be level. The drain trap should be primed with water after installation. The drain line must be pitched away from the case enough to ensure proper drainage, typically at least 1/4" per foot. Consult your local codes for minimum requirements.

The forward drain section, tee, and "R" trap are shipped loose for field installation.

FIGURE 16: Properly Leveled Doors



FIGURE 17: Center Locking Screw

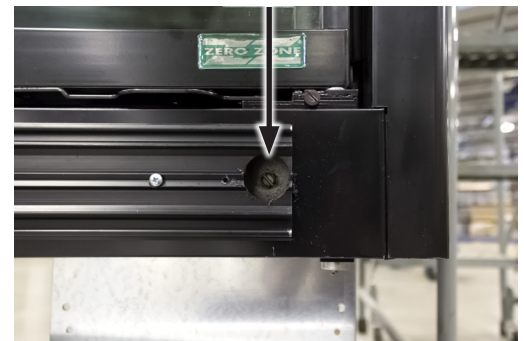

FIGURE 18: Top Mounting Plate

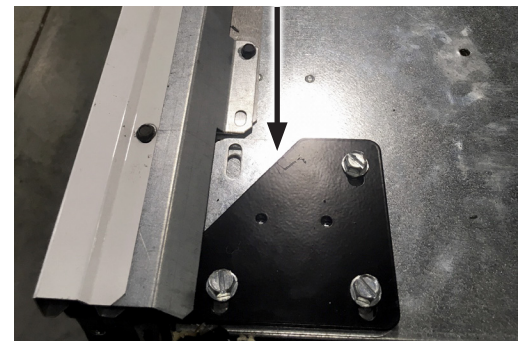

FIGURE 19: Drain Installation



INSTALLATION & OPERATION

Kickplates

Each case is shipped with a front kickplate. Cases with end panels are shipped with 1 side kickplate per end panel. Cases that join together are shipped with a kickplate splice.

Front and side kickplates are attached to the case bases using Tinnerman clips. Position the front kickplate so the flange is on top and facing outward. The screw (supplied) goes through the kickplate and into the Tinnerman clip (See Figure 20).

1. Install Tinnerman clips at each base.
2. Install side kickplate.
3. Install front kickplate.
4. Insert fasteners to secure kickplates.

There is a natural gap between the top of the kickplate and the underside of the Reveal Merchandise® that allows airflow of 20 CFM/foot. If more airflow is required, contact the factory to order optional louvered kickplates (provides 60 CFM/foot).

FIGURE 20: Kickplate Installation

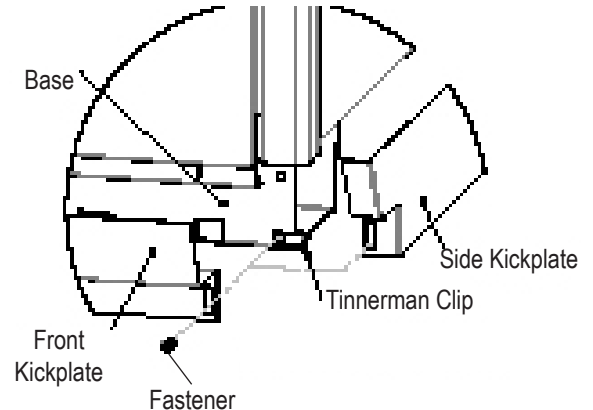

Bumper

Cases are supplied with a protective bumper shipped loose on top of each case. The steel bumper support and snap track are factory-installed on the front of the case. The bumper may need trimming before snapping it onto the snap track. Door leveling must be completed before attaching the bumper (See "Door Leveling (Door Sag/Sawtooth)" on page 12).

Top Trim

Top trim is factory installed to hide the door hardware located on the top exterior of the case. The top trim is held up by end and center support braces. The center support brace also acts as a joint support brace (See Figure 21). The joint support brace will be shipped loose. After the cases are joined together, add the support brace under the top trim and attach it to both cases using the existing holes.

FIGURE 21: Top Trim Center/Joint Support Brace

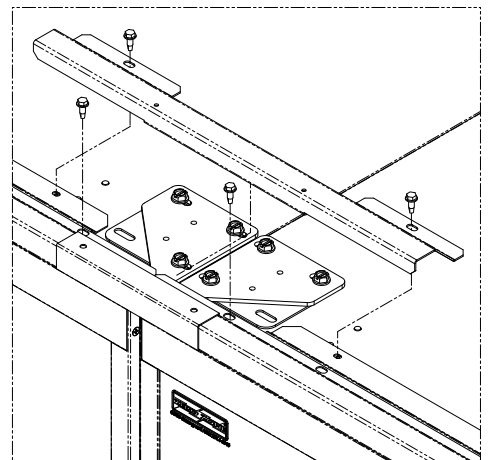

CoolView® Doors

Door leveling must be completed before attaching the bumper (See "Door Leveling (Door Sag/Sawtooth)" on page 12).

COOLARC™ DOOR HANDLES

The CoolArc™ door handle is attached to the glass surface of the door by an industrial-grade adhesive.

INSTALLATION & OPERATION

ADJUSTING DOOR CLOSER/POWER CARTRIDGE TENSION

The power cartridge is a spring cartridge that automatically closes the door. It is located on the hinge-side of the door sill. A square pin protruding from the top of the power cartridge fits into a square opening on the door, transferring the spring tension to the door. This means that the square pin must be aligned with the square opening when installing a door. An adjustment screw on the front of the power cartridge can be used to increase or decrease tension.

1. Open the door to observe current door tension. A properly tensioned door will close itself gently and not swing open.
2. Use a flathead screwdriver to turn the door tension screw (**See Figure 22**). **Do not use power tools; a screwdriver allows for more control.**
3. To increase tension, hold the door open 2" and turn the screw counterclockwise until the door begins to close. After it closes, increase tension by 2 more turns.
4. To decrease tension, turn the screw clockwise.

The screws holding the door closer are secured with removable thread locking compound; extra force will be necessary to remove them.

HOLD-OPEN BRACKET

CoolView® doors are self-closing, and closing tension increases as the door opens wider. The hold-open bracket keeps the door open when engaged, which is useful for stocking shelves or case maintenance. To engage the hold-open bracket, open the door to 90° until it clicks. Closing the door to about 80° will release tension on the door, and it will self close again.

DOOR GASKET

Upper and lower horizontal magnetized gaskets run the length of each case. The gaskets mate up to steel plates installed at the top and bottom of each door. A sweeper gasket runs along the handle-side of each door. A specialized gasket runs along the hinge-side of left-hinged doors, with very few exceptions.

INSTALLING A DOOR

⚠ CAUTION! THE DOORS ARE HEAVY. IT IS RECOMMENDED THAT TWO INDIVIDUALS COMPLETE THE DOOR INSTALLATION TO PREVENT INJURY TO PERSONNEL AND DAMAGE TO THE DOOR.

⚠ CAUTION! FOR SAFETY, DO NOT LIFT THE DOOR BY THE HANDLE.

1. Align the door hinge bracket on the bottom of the door with the square pin on the power cartridge (**See Figure 23**).
2. Tilt the door into place, then install the door shoulder bolt and bushing on top of the hinge side of the door (**See Figure 24 on page 15**).
3. Install the hold-open bracket located next to the power cartridge on the door sill.
4. Perform the "**Adjusting Door Closer/Power Cartridge Tension**" procedure on page 14.

FIGURE 22: Door Tension Screw

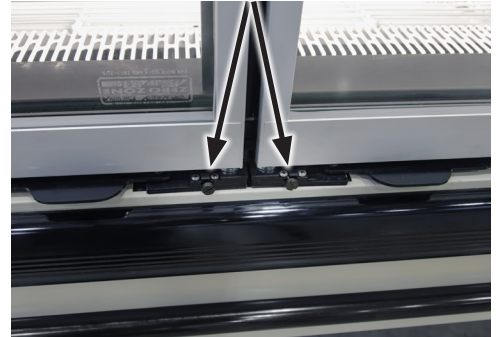
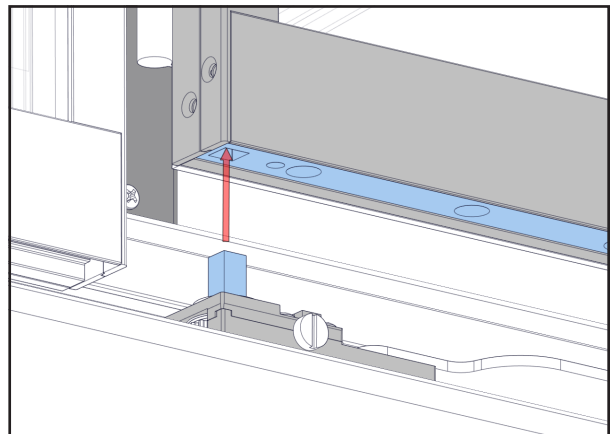

FIGURE 23: Door Hinge Bracket and Power Cartridge
View of Bottom of Door



INSTALLATION & OPERATION

REMOVING A DOOR

CAUTION! THE DOORS ARE HEAVY. IT IS RECOMMENDED THAT TWO INDIVIDUALS COMPLETE THE DOOR REMOVAL TO PREVENT INJURY TO PERSONNEL AND DAMAGE TO THE DOOR.

CAUTION! FOR SAFETY, DO NOT LIFT THE DOOR BY THE HANDLE.

Note: *The top trim piece must be removed to access the door shoulder bolt.*

1. Turn door tension screw clockwise until door does not close on its own. This removes tension between the door and power cartridge.
2. Remove the bolt connecting the hold-open bracket to the door. The hold-open bracket is located next to the power cartridge and connects to the bottom of the door.
3. Remove shoulder bolt and bushing on the top of the hinge-side of the door (**See Figure 24**). Only remove the bolt holding the door; do not remove the bolts attached to the case.
4. Tilt the door away from the case. **Note: The door is heavy. Be prepared to hold the weight of the door.**
5. Lift the door up and clear of the power cartridge and set down carefully.

FIGURE 24: Door Shoulder Bolt

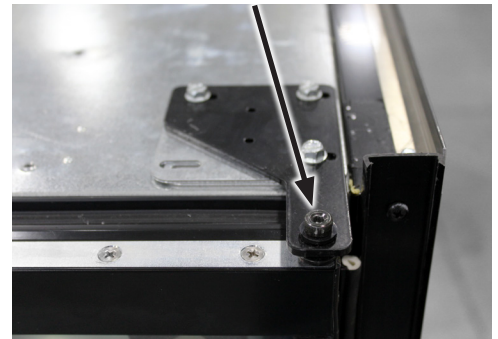

Shelves & Stocking Product

Shelf location may be adjusted in 1" vertical increments in any position for best display advantage. Make sure the shelf brackets are securely seated before placing any product on the shelf. The standard shelves may be tilted down at a 10° angle. Optional shelf assemblies are available that may be tilted at 5°, 10°, or 15° angle.

The case may be stocked with product after it has operated at least 24 hours with correct case temperature and proper control operation. When stocking the shelves, leave at least a 1" gap between the product and the shelf above, which allows air to circulate over and around the product. Product should not extend beyond the front of the shelves or bottom wire rack. **Note: Do not place product on the return air grille. Do not exceed shelf load capacity (See Figure 26 on page 15). Do not stand on the case when stocking or adjusting shelves.**

To unassemble a shelf, insert a putty knife between the side of the shelf and the shelf bracket. Pry the pieces apart to disengage the bracket.

Shelves can be ordered with 1", 2", or 3" acrylic product stops, which fit into aluminum price tag molding. Slide the product stop into the price tag molding and push it down to the bottom of the channel (**See Figure 26**). The channel of the price tag molding may need to be pried open with a screwdriver, but the product stop should slide in easily once started.

FIGURE 25: Shelf Load Capacities

SHELF TYPE	WIDTH	DEPTH	BRACKET TYPE	LOAD CAPACITY (LBS.)
Solid Shelf	36" 48"	22"	2-Position (0°/10°)	350/150
			4-Position (0°/5°/10°/15°)	350/250/150/100
		24"	2-Position (0°/10°)	350/150
			4-Position (0°/5°/10°/15°)	350/250/150/100
		27"	2-Position (0°/10°)	350/150
		Note: 36" width only for 6' Reveal™ Cases		

FIGURE 26: Acrylic Product Stops (1" Shown)



Product stop fits into the price tag molding.

REFRIGERATION

⚠ WARNING! REFRIGERATION SYSTEMS USING R-744 (CO₂) ARE UNDER HIGH PRESSURE. DO NOT TAMPER WITH THE SYSTEM. CONTACT QUALIFIED SERVICE PERSONAL BEFORE DISPOSAL.

Symbols and Definitions



Symbol ISO 70000-1701 (2004-01)

Pressure

Mechanical Components

FIGURE 27: Fans and Case-to-Case Piping



FIGURE 28: Expansion Valve Next to Evaporator Coil



Air is circulated through the display case by evaporator fans, which are located below the deck pans in the bottom of the case (See Figure 27). Air is drawn through the front return air grill and discharged out of the honeycomb at the top.

The evaporator coil, located at the rear bottom of the case, can be inspected by removing the deck pans. Unless otherwise specified, the thermostatic expansion valve (TXV) is mounted to the evaporator coil (See Figure 28). Superheat should be adjusted to 6-10°F. Contact Zero Zone for high-glide refrigerants.

Glycol cases typically have a balance valve located in the outlet line inside of the case. If a stop solenoid is provided, it will also be located in the outlet line. Schrader valves are provided inside the case on the right-hand side of the coil for venting and draining the system.

Refrigerant Piping

The display case must be connected to a refrigeration unit using the same refrigerant indicated on the display case serial tag.

Correct refrigeration line sizing and industry standard installation practices are essential for proper system operation. Zero Zone offers many refrigerant choices. We recommend using the Sporlan Virtual Engineer Toolbox to calculate sizing for liquid, suction, and discharge lines: <https://solutions.parker.com/sporlanvirtualengineer>. Go to the link, select the line type, and then enter the information required to calculate the recommended line size. Toggle between metric or imperial units as needed.

REFRIGERATION

After connections have been made, the refrigeration access hole in the case must be sealed completely with an aerosol-dispensed urethane insulation or equivalent (example: *Great Stuff*). Penetrations made in sheet metal baffles should also be sealed.

Cases will be equipped with a liquid-line filter drier by default.

FIGURE 29: Case Temperature Internal Control Options

SETTING	ORMC83D & ORMC88D		
Evaporator Temp	28°F		
Return Air Temperature Set Point	30°F		
Return Air Temperature Differential	4°F		
Discharge Air Temperature Set Point	33°F		
Discharge Air Temperature Differential	4°F		
SETTING	R-404A	R-448A	Sat. Temp
Condensing Unit Cut-In	74 psig	62 psig	33°F
Condensing Unit Cut-Out	62 psig	51 psig	25°F
<p>Note: Set points based on superheat of 6-8°F. For high-glide refrigerants, use dew point for unit sizing. Adjust evaporator pressure as needed to maintain discharge air temperature. To receive the full benefit of high-glide refrigerant properties, the superheat may need to be lowered to 4-6°F. Contact Zero Zone with questions.</p>			

Operation Set Points

Refer to the case spec sheet for Btu/h requirements and electrical requirements. Operate the case at the proper settings to maintain correct product temperature, per food safety regulations (**See Figure 29 on page 17**). **Note: Set points are based on flat shelves. Alternate shelving—such as angled or tiered shelving, peg hooks, or produce inserts—may require lower operating temperatures.**

FIGURE 30: Defrost Settings

SETTING	ORMC83D & ORMC88D
Defrost Type	Off-Cycle
Frequency	2 Per Day
Duration	30 Minutes

REFRIGERATION

Off-Cycle Defrost

Periodic defrosting is necessary to keep the evaporator coil free of frost. **See Figure 30** for defrost settings.

During off-cycle defrost, refrigerant is stopped either by stopping the compressor or by closing the liquid line solenoid valve and allowing the compressor to pump down. The fans and lights remain on during off-cycle defrost.

If temperature termination is selected, set the termination temperature for 45°F for discharge air and coil temperature. **Note: Opening the doors, stocking product, or shopping during off-cycle defrost may cause premature defrost termination.**

Case Thermometer

An NSF thermometer is shipped loose and should be installed in the warmest product location as required by NSF. Specific field installation instructions are packaged with the NSF thermometer.

ELECTRICAL

General

CAUTION! DISCONNECT POWER TO THE CASE BEFORE SERVICING ELECTRICAL COMPONENTS TO AVOID PERSONAL INJURY AND DAMAGE TO THE UNIT.

CAUTION! A DISCONNECT NEEDS TO BE INCORPORATED IN THE FIXED WIRING.

Cases will have 2 electrical circuits for the fan circuit and the lighting circuit.

The electrical enclosure is located behind the lower trim on the right side of the case. The enclosure includes the power connection and power supplies for the LED light sticks. The light switch is located on the front right side of the false ceiling (See Figure 31). When supplying electrical power to the case, connect to the supplied black and white wires and wire nuts inside the electrical enclosure. A ground connection should also be connected inside the electrical enclosure. See Figure 32 for typical wiring diagram with off-cycle defrost.

Note: Always refer to the wiring diagram shipped with the case.

Optional top electrical will be located in a junction box on top of the case.

External wiring should be sized according to the amperage rating stamped on the serial tag, which is located on the ceiling inside the left-hand door. Typical electrical values are shown on specification sheets that are available online. All internal wiring has been completed at the factory.

All wiring must comply with the National Electrical Code (NEC) and all local codes. After installing the equipment, correct operation of the electrical circuits, controls, and defrost controls should be verified. All operating voltages and amperages should be measured and recorded. Display cases that do not include a remote disconnect must be field installed with a remote disconnect in accordance with NFPA 7.0 of the National Electric Code.

In coolers, 1 sensor bulb is factory installed. Temperature probe wires are white (common) and green (supply). The temperature probe (discharge air) is located in the false ceiling.

FIGURE 31: Light Switch



FIGURE 32: Sample Wiring Diagram

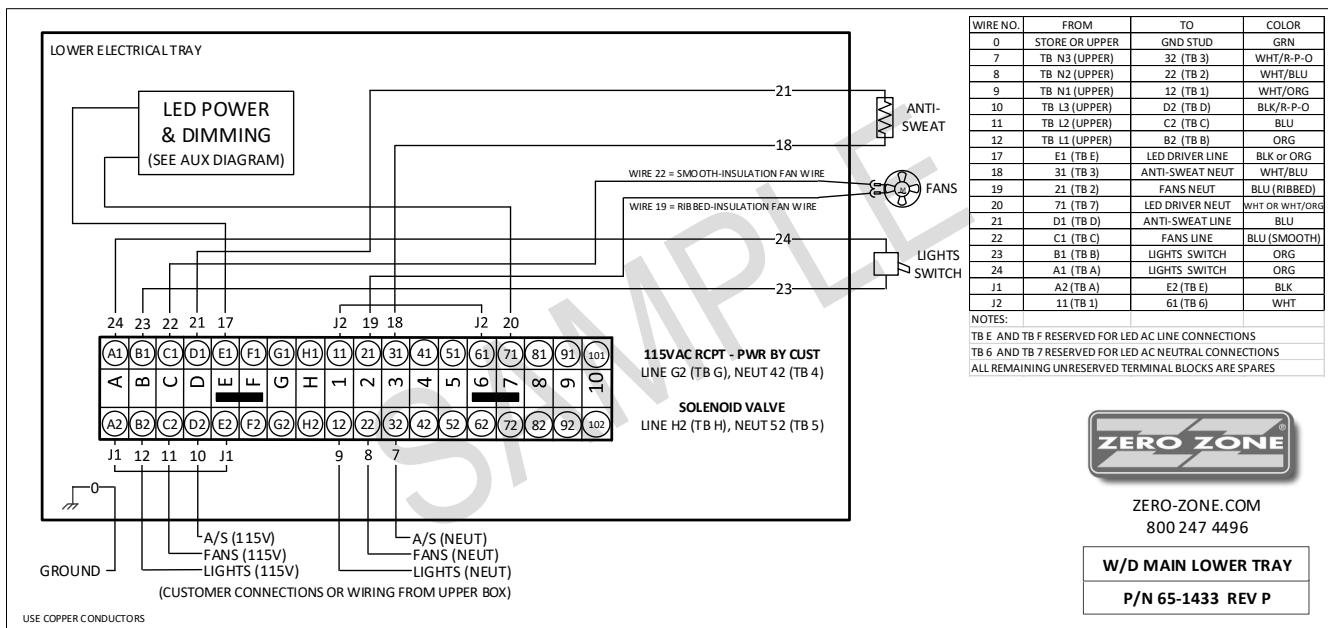

MAINTENANCE

Cleaning

Although each Zero Zone display case is thoroughly cleaned before shipping, the cases should be thoroughly cleaned again before start-up and routinely thereafter to maintain a clean appearance. With just a few minutes of cleaning each week, the case will remain in top condition.

1. Do not use high-pressure water or steam to clean the interior or any components.
2. Do not wash fan motors. A damp cloth can be used to wipe the fan motors. Cover the fan motors with a plastic bag when washing the case.
3. Wipe out the case interior using mild detergent and warm water (never an abrasive cleaner).
4. Clean all glass doors, windowed ends, and mirrors using glass cleaner. Cleaning interior glass reduces fogging and increases visibility. If your doors have an anti-fog coating, do not use any cleaning products containing silicone.
5. Internal components can be cleaned after removing coil covers, access panels, and sheet metal components. Use a mild detergent and warm water or a mild sanitizer.
6. If the case is equipped with a condensate pan and pump, the drain should be blocked before washing coils. Water can be removed with a shop vacuum.
7. Coils may be cleaned with a garden hose or pails of water. If the case is equipped with a condensate pan and pump, cases should be cleaned with a minimal amount of water so the evaporator, pump, and drain pans do not get overfilled.
8. The case drain should frequently be cleaned of debris to prevent clogging. If water is not draining, check to see if the drain is clogged. A clean-out tee can be accessed from the front of the case behind the kickplate.

UNDER CASE FLOOR CLEANING (NSF)

The floor under your Zero Zone display case can be cleaned by following these steps:

1. Remove the fasteners attaching the kickplate to the case. The fasteners are accessed from the front of the unit.
2. With the kickplates removed, vacuum under the case to remove any dirt, debris, and dust build-up.
3. Mop under the unit using non-abrasive floor cleaner and warm water.
4. When finished mopping, squeegee any remaining water under the display unit to the store floor drains to speed up the drying process. Replace the kickplates when the floor has dried.



For other technical support, please refer to
the Technical Resources page at:

WWW.ZERO-ZONE.COM

or contact the Zero Zone Service Department at:

800-247-4496

All specifications subject to change without notice.

