



CRYSTAL
merchandiser®

Crystal Merchandiser® RVMC24 Specs

Medium Temp Reach-In Remote Display Cases

2-Door, 3-Door, 4-Door, and 6-Door Cases

Quick Specs

Energy (Btu/h per Door)*

Standard: 410 at 28°F Evaporator

*when used with parallel rack system

Merchandising (6-Door)

Facings: 69.8 ft²

Packout: 133.4 ft³ with 24" x 24" deep shelves

Features & Options

Go Green

Remote cases ready for CO₂. 90-bar rating available.

High Humidity

Control climate challenges with our advanced humidity package

CoolView® Doors

24" wide x 74" tall CoolView® Ultra® Doors

LED Lighting

ChillBrite® 3500K or 4000K LED Lighting

Additional Models

The Crystal medium temp lineup offers cases with 30" doors and an optional bottom coil design.

Hybrid™ Display Case

Available as Hybrid™ cases with R-404A or R-448A

Applications

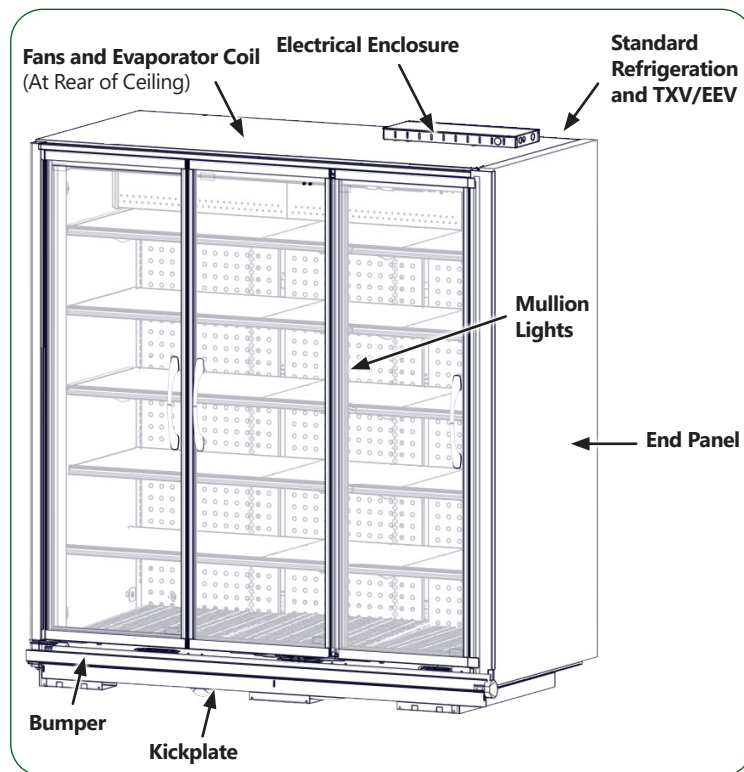

Manuals and Instructions:
<https://www.zero-zone.com/rvmc-rvlc>



Contact Us:

800-247-4496

www.zero-zone.com

Specifications are subject to change without notice. All dimensions are nominal.
Case designed to operate in an ambient temperature of 75°F and relative humidity of 55% or lower.



SS-23 Rev T • 5/7/2026

© 2026 Zero Zone, Inc.

Page 1 of 5





Refrigeration Data



Set Points	°F
Evaporator Temperature ¹	28
Discharge Air Temperature (w/ 8°F Superheat)	33

Notes:

- For high-glide refrigerants, use dew point for unit sizing. Adjust evaporator pressure as needed to maintain discharge air temperatures.



Energy Use with Parallel Rack System ²	Lineup Data	Individual Case Data (includes 1 pair of end panels)			
	Per Door Avg	2-Door	3-Door	4-Door	6-Door
RVMC24 Baseline Btu/h	410	930	1,360	1,740	2,560
Energy Use with Condensing Unit ²	Per Door Avg	2-Door	3-Door	4-Door	6-Door
RVMC24 Baseline Btu/h	440	1,005	1,470	1,880	2,765
Btu/h Adders	Per Door Avg	2-Door	3-Door	4-Door	6-Door
Rail Heated Doors (Zero Zone CoolView® Ultra®)	+10	+20	+30	+40	+60
Rail & Glass Heated Doors (Zero Zone CoolView® Ultra®)	+30	+60	+90	+120	+180
End Panels	Btu/h Per Case				
Glass Windowed End Panel (1-Pair) ³	+410				

Notes:

- Baseline Evaporator Btu/h based on LED lighting (Zero Zone ChillBrite® 4000K), no-energy doors (Zero Zone CoolView® Ultra®), and ECM or SSC electronic fan motors.
- Glass windowed end panels only available with 2 1/2" end panels.

Glycol Data ⁴	2-Door	3-Door	4-Door	6-Door
Flow Rate (GPM)	0.6	0.8	1.2	1.8
Pressure Drop (PSIG)	2.0	3.3	6.1	5.8

Notes:

- All Glycol data based on 35% propylene glycol by weight, 20°F supply temperature, and 23°-24°F outlet temperature.



Refrigeration Piping: R-404A, R-448A & R-454C ⁵	Outlet Size (in.)			
	2-Door	3-Door	4-Door	6-Door
Suction Line O.D. (Top Refrigeration Exit)	1/2	1/2	1/2	1/2
Liquid Line O.D.	3/8	3/8	3/8	3/8
Refrigeration Piping: CO ₂ ⁵	2-Door	3-Door	4-Door	4-Door
Suction Line O.D. (Top Refrigeration Exit)	3/8	3/8	3/8	3/8
Liquid Line O.D.	3/8	3/8	3/8	3/8

Notes:

- Individual risers for circuits of more than one case require refrigeration line sizing by Zero Zone. Refer to the Installation & Operation Manual for details.



Electrical & Energy Data ⁶



Fan Motors (115V)	Per Door Avg		2-Door		3-Door		4-Door		6-Door	
Number of Fans	--		2		2		2		3	
Fan Motors (115V)	Amps	Watts	Amps	Watts	Amps	Watts	Amps	Watts	Amps	Watts
High-Efficiency Electronic (ECM or SSC)	0.42	8	0.84	15	0.84	22	.84	25	1.26	31
Lighting System (120V)	Amps	Watts	Amps	Watts	Amps	Watts	Amps	Watts	Amps	Watts
Same-Swing Doors (Fig. 1: Options A & B)	0.16	19	0.33	39	0.48	58	0.64	77	1.00	115
French-Swing Doors (Fig. 1: Options C, D, E, F for 3-Door)	0.15	18	0.30	36	0.53	64	0.60	72	0.90	108
Anti-Sweat Heat (115V)	Amps	Watts	Amps	Watts	Amps	Watts	Amps	Watts	Amps	Watts
No-Energy Doors (Zero Zone CoolView® Ultra®)	0.00	0	0.00	0	0.00	0	0.00	0	0.00	0
Rail Heated Doors (Zero Zone CoolView® Ultra®) ⁷	0.05	6	0.09	10	0.14	16	0.19	22	0.28	32
Rail & Glass Heated Doors (Zero Zone CoolView® Ultra®) ⁷	0.16	18	0.31	36	0.47	54	0.63	72	0.94	108

Notes:

- 6. Amps are based on electrical nameplate values. Watts are based on laboratory observations of actual energy use.
- 7. High-humidity package includes glass heat, rail heat, and mullion heat.

Physical Data



Merchandising	2-Door	3-Door	4-Door	6-Door
Facings (ft. ²)	23.7	35.2	46.7	69.8
Packout (ft. ³) 22" Shelves	42.8	63.6	81.5	121.8
Packout (ft. ³) 24" Shelves	46.3	68.8	89.3	133.4
Weight without End Panels	2-Door	3-Door	4-Door	6-Door
RVMC24 Weight (lbs.)	775	933	1,020	1,254
Shipping Weight with Solid End Panel ⁸	2-Door	3-Door	4-Door	6-Door
RVMC24 Weight (lbs.)	835	993	1,080	1,314
Shipping Weight with Solid Windowed End ⁸	2-Door	3-Door	4-Door	6-Door
RVMC24 Weight (lbs.)	885	1,043	1,130	1,364

Notes:

- 8. Each solid end panel: 30 lbs. Each Windowed End: 55 lbs.

FIG. 1: 3-Door Configuration Options

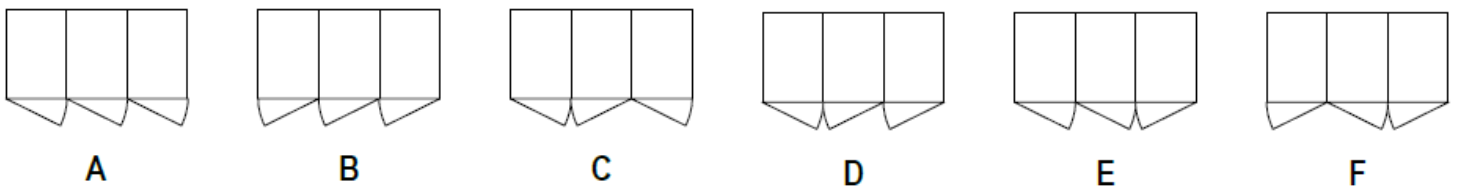



Crystal Merchandiser® RVMC24 Remote Specs

RVMC24 Top View

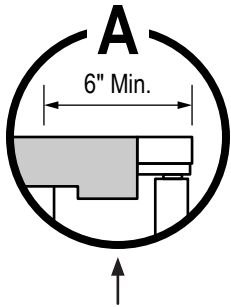

Building soffits must be set back at least 6" from the front of the doors to allow access to electrical wiring on the top of the case.

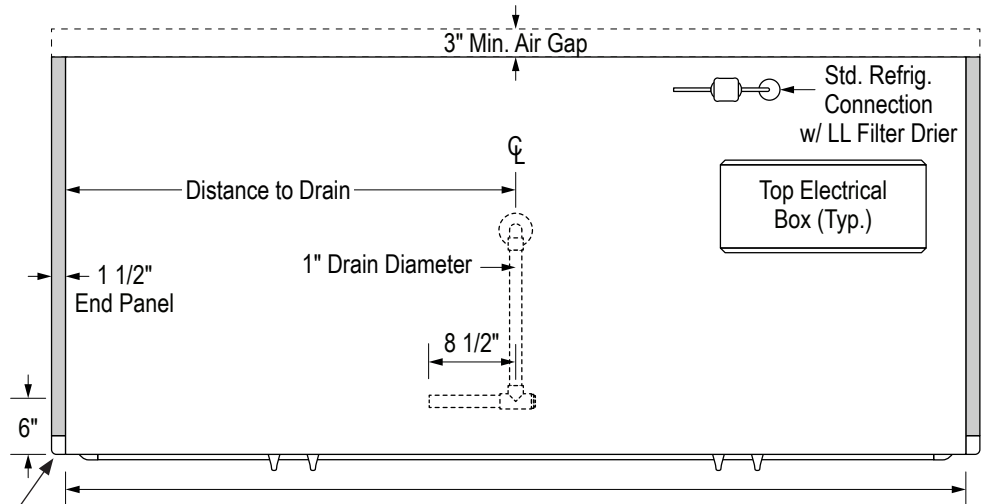

Case Dimensions

Measurements	2-Door	3-Door	4-Door	6-Door
Case Length (in.) without End Panels	48 3/4	72 1/2	96 3/8	143 7/8
Case Length (in.) with End Panels	53 3/4	77 1/2	101 3/8	148 7/8
Distance to Drain (in.) without End Panels	24 3/8	36 1/4	48 1/8	71 7/8

RVMC24 End View

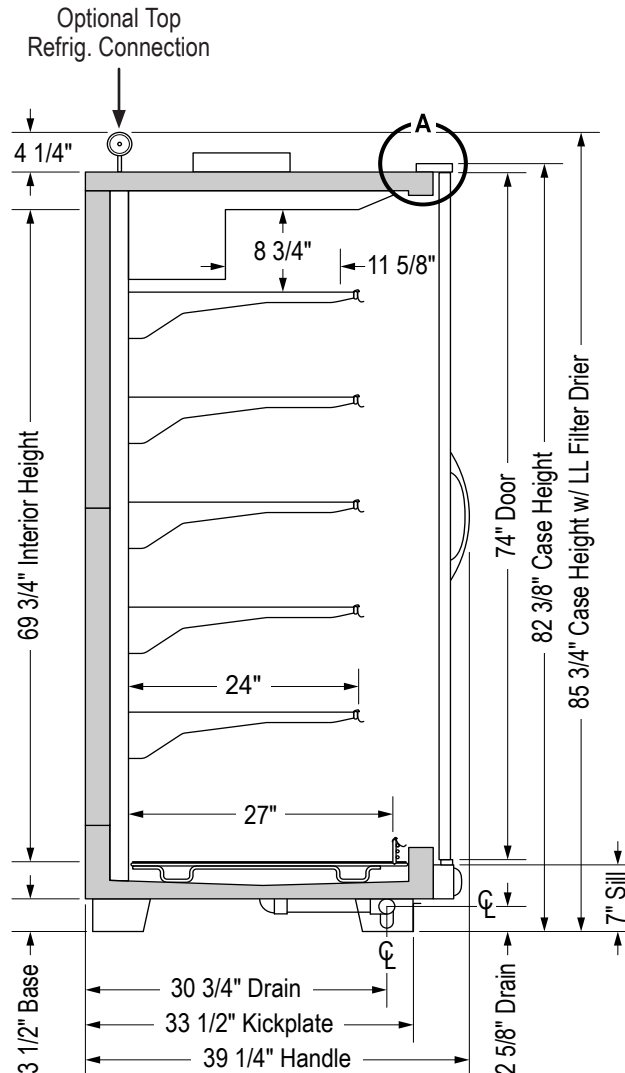



R454C RVMC24 End View

Case Notes:

- Each A2L case includes a 4 1/2" kickplate, refrigeration outlet located at the top right, and the electronic egress for case power and sensors exit through the top.
- Case total height subject to change.
- The leak detector is located internally to the display case.
- The mitigation fans are located on the end kickplates.
- Features not available in A2L: Hybrid, High Humidity, Ref. to bottom, Elec. to bottom, Light dimming, Condensate Pump or Evaporator Pan.

