

CRYSTAL
merchandiser®



ZERO ZONE

CRYSTAL MERCHANDISER® COOLERS RVMC

With CoolView® Doors and ChillBrite® LED Lighting

INSTALLATION & OPERATION MANUAL



66-0014 REV J • MAR 2026



Table of Contents

ZERO ZONE WARRANTY	1
INTRODUCTION	2
INSTALLATION & OPERATION	4
■ Delivery Inspection.....	4
■ Packaging.....	4
■ Location.....	4
■ Moving Cases.....	5
■ Optional Bases.....	5
■ Leveling.....	6
■ Lineup Assembly.....	13
■ Ultra Narrow Case Anchoring.....	18
■ Door Leveling (Door Sag/Sawtooth).....	19
■ Bottom Mounting Plate.....	19
■ Top Mounting Plate.....	19
■ Drain.....	19
■ Condensate Removal System.....	20
■ Kickplates.....	20
■ Bumper.....	20
■ Top Trim.....	20
■ CoolView® Doors.....	20
■ CoolArc™ Door Handles.....	20
■ Hold-Open Bracket.....	21
■ Door Gasket.....	21
■ Door Closer / Adjusting Door Tension.....	21
■ Removing a Door.....	21
■ Installing a Door.....	22
■ Rear Load Cases.....	22
■ Shelves & Stocking Product.....	23
REFRIGERATION	24
■ Mechanical Components.....	24
■ Evaporator Fans.....	24
■ Expansion Valve.....	24
■ Additional Valves.....	24
■ Refrigerant Piping.....	24
■ Leak Check, Evacuation, & Charging.....	24
■ Operation Set Points.....	25
■ Defrost.....	25
■ Case Thermometers.....	25
ELECTRICAL	26
■ General.....	26
MAINTENANCE	27
■ Cleaning.....	27
■ Under Case Floor Cleaning (NSF).....	27

When installing a Crystal Merchandiser® in a Hybrid™ configuration, refer to both this manual and the Hybrid™ Installation & Operation Manual.

ZERO ZONE WARRANTY

Limited Warranty

Zero Zone, Inc. (Seller) hereby warrants that any products manufactured by it and sold are warranted to be free from defects in material and workmanship, under normal use and service for its intended purpose, for a period of one (1) year from the date of original installation (not to exceed 15 months from the date of factory shipment). Zero Zone ChillBrite® LED Lighting carries a 5-year parts warranty. Zero Zone CoolView® Doors carry a 10-year glass pack parts warranty. The obligation under this warranty shall be limited to repairing or exchanging any part, or parts, FOB Factory, which is proven to the satisfaction of the Zero Zone Service Department to be defective. Zero Zone reserves the right to inspect the job site, installation, and reason for failure. This limited warranty does not cover labor, freight, or loss of food or product, including refrigerant loss. This warranty does not apply to motors, switches, controls, lamps, driers, fuses, or other parts manufactured by others and purchased by the Seller unless the manufacturer of these items warrants the same to the Seller, and then only to the extent of those manufacturer's warranty to the Seller. Any products sold on an "AS IS" basis shall not be covered by this warranty.

Extended Warranties

In addition to the standard limited warranty, for further consideration, the Seller will extend to the original purchaser prior to shipment, a limited extended warranty on the compressor only, following expiration of the standard warranty. The Seller agrees to repair or exchange, at its option, or provide reimbursement for such exchange as directed, less any credit allowed for return of the original compressor, of a compressor of like or similar design and capacity, if it is shown to the satisfaction of Zero Zone that the compressor is inoperative due to defects in factory workmanship or material under normal use and services as outlined by Zero Zone in its Installation & Operation Manuals and other instructions.

Length of Extended Warranty

Any compressor warranty may be extended for an additional four (4) years, but such extension must be purchased prior to shipment to be effective. This warranty is only for the compressor and not for any other associated parts of the refrigeration system.

Product Not Manufactured by the Seller

The written warranty, if any, provided by the manufacturer of any part of the refrigeration unit sold by Seller to Buyer, but not manufactured by Seller, is hereby assigned to the Buyer. However, Seller makes no representation or warranty regarding the existence, validity, or enforceability of any such written warranty.

Limitation and Exclusion of Warranties

THE WARRANTIES SET FORTH HEREIN ARE EXCLUSIVE AND IN LIEU OF ALL OTHER WARRANTIES AND REMEDIES WHATSOEVER, INCLUDING, BUT NOT LIMITED TO, IMPLIED WARRANTIES OF MERCHANTABILITY AND/OR FITNESS FOR A PARTICULAR PURPOSE.

INTRODUCTION

Important User Information

Copyright © 2026 Zero Zone, Inc.

All rights reserved. No part of the contents of this manual may be reproduced, copied, or transmitted in any form or by any means including graphic, electronic, or mechanical methods or photocopying, recording, or information storage and retrieval systems without the written permission of the publisher, Zero Zone, unless it is for the purchaser's personal use.

The information in this manual is subject to change without notice and does not represent a commitment on the part of Zero Zone. Zero Zone does not assume any responsibility for any errors that may appear in this manual. In no event will Zero Zone be liable for technical or editorial omissions made herein, nor for direct, indirect, special, incidental, or consequential damages resulting from the use or defect of this manual.

The information in this document is not intended to cover all possible conditions and situations that might occur. The end user must exercise caution and common sense when installing, using, or maintaining Zero Zone products. Zero Zone products should only be installed by qualified, professional refrigeration technicians. If any questions or problems arise, call Zero Zone at 800-247-4496.

Any change to a Zero Zone product made during the installation, start-up, or at any other time must be submitted in writing to Zero Zone for approval and be approved by Zero Zone in writing prior to commission. The product warranty is voided when any unapproved change is made to a Zero Zone product.

Manufacturer

Zero Zone, Inc.

110 N Oakridge Dr • North Prairie, WI 53153 • 800-247-4496 • www.zero-zone.com

Intended Use

Zero Zone products are intended to be installed and used as described in this manual and other related Zero Zone literature, specifications, drawings, and data. All Zero Zone products must be leveled after being installed.

This appliance is not intended for use by persons (including children) with reduced physical, sensory, or mental capabilities, or lack of experience and knowledge, unless they have been given supervision or instruction concerning use of the appliance by a person responsible for their safety. Children should be supervised to ensure that they do not play with the appliance.

Do not store explosive substances such as aerosol cans with a flammable propellant in this appliance.

Testing Standards

These display cases were designed and tested using the following industry standards:

- NSF 7 – Commercial Refrigerators and Freezers (ANSI Approved) (equipment certified by NSF)
- NSF 51 – Food Equipment Materials (ANSI Approved) (equipment certified by NSF)
- UL 471 – Commercial Refrigerators and Freezers (ANSI Approved) (equipment certified by ETL)
- ASHRAE Standard 72 – Method of Testing Commercial Refrigerators and Freezers (ANSI Approved)
- AHRI 1200 – Performance Rating of Commercial Refrigerated Display Merchandisers and Storage Cabinets (ANSI Approved)
- DOE Compliant (All U.S. Sales and U.S. Territories)

ASHRAE Standard 72 specifies the test conditions for the equipment. It includes the ambient conditions of 75°F dry bulb and 55% RH. It also specifies the door opening requirements for the performance test. Doors are opened six times in one hour for six seconds. The door opening test period is for eight hours during one 24-hour performance test. As an example, a 5-door case will have 240 door openings during one 24-hour test. Consult the factory if your store exceeds these test conditions.

INTRODUCTION

Display Case Models

The information contained in this manual pertains to the following Zero Zone display cases:

CASE MODEL	DESCRIPTION	DOOR SIZE & TYPE
RVMC24	Standard Case	24" x 74" CoolView® Ultra™ French Doors
RVMC24D	Deep Case	24" x 74" CoolView® Ultra™ French Doors
RVMC24DRL	Deep Rear Load Case	24" x 74" CoolView® Ultra™ French Doors
RVMC24RL	Rear Load Case	24" x 74" CoolView® Ultra™ French Doors
RVMC24UN	Ultra Narrow Case	24" x 74" CoolView® Ultra™ French Doors
RVMC24BBUN	Back-to-Back Ultra Narrow Case	24" x 74" CoolView® Ultra™ French Doors
RVMC30	Standard Case	30" x 74" CoolView® Ultra™ Doors
RVMC30D	Deep Case	30" x 74" CoolView® Ultra™ Doors
RVMC30DRL	Deep Rear Load Case	30" x 74" CoolView® Ultra™ Doors
RVMC30RL	Rear Load Case	30" x 74" CoolView® Ultra™ Doors

Case Features

Zero Zone produces high quality refrigerated display cases using state-of-the-art components. The cases are built with the thickest insulation in the industry and a high efficiency evaporator coil. Case features include:

- Brushless DC electronic motors
- Zero Zone ChillBrite® LED Lighting
- Zero Zone CoolView® Ultra™ Doors

INSTALLATION & OPERATION



CAUTION!

DO NOT STAND ON TOP OF A CRYSTAL MERCHANDISER®. THE TOP OF THE CASE IS NOT DESIGNED TO SUPPORT THE WEIGHT OF A PERSON.

Delivery Inspection

Zero Zone display cases are carefully factory-tested, inspected, and packed to ensure delivery in the best possible condition. The equipment should be unwrapped and checked for damage **immediately** upon delivery. **DAMAGE MUST BE NOTED AT TIME OF DELIVERY, AND ALL CLAIMS FOR DAMAGES MUST BE FILED WITH THE TRANSPORTATION COMPANY, NOT WITH ZERO ZONE.** The carrier will supply necessary report and claim forms. Contact your Zero Zone sales representative or the service department to arrange for replacement parts.

Do not leave, store, or hold case outdoors in direct sunlight or high ambient temperature. With the end panels on, the case is airtight; the inside temperature of the case will increase, and the heat will be unable to escape. This could potentially cause any plastic inside the case to deform or warp.

Packaging

Each **case** in a lineup is labeled to identify the **lineup** and **joint**. The label uses a two digit number designation, separated by a decimal. The first number indicates the case lineup. The second number indicates the case joint. Case joints begin with the number “1” at the left-most joint in the lineup when looking at the front of the lineup. The first case in the lineup will be labeled on the right end and the second case in the lineup will be labeled on the left end. The numbers on each end to be joined will match (**See Figure 1**).

FIGURE 1: Case Label Information

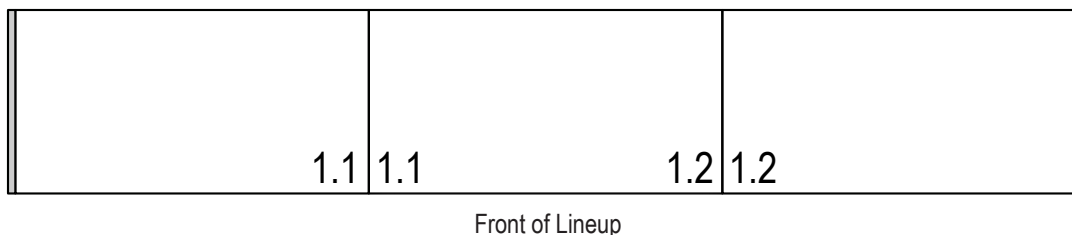

The *first* case in a lineup (with the right side labeled “x.1”) has a packet attached to the shelving that contains touch-up paint. *Every* case in a lineup has a packet attached to the shelving that contains important information about the case and/or lineup and, if applicable, special instructions for installing ordered options.

Bumpers and kickplates are shipped on top of the case. Shelves for the case are tie-wrapped and blocked into the individual cases. Other accessories like drain traps, drain pans, condensate evaporation pans, and hat channel rails are shipped in the case that require the parts.

Materials for joining cases—including caulk, joining bolts, splices, and end filler posts—are shipped in each case to be joined.

The doors are prevented from opening during shipment with the use of a door-holding shipping bracket. The bracket is screwed to the top of the case at each door and should be removed when the case is unpacked.

Location

Zero Zone cases must not be installed in the direct rays of the sun or near a source of radiant heat. Be certain that the floor under the installation is of sufficient strength to prevent sagging. Uneven surfaces will result in reduced performance.

Cases should be set to allow a minimum 3" of space behind the back of the units. This will allow necessary air to circulate behind the display cases and prevent condensation. Higher humidity stores with minimal air circulation require at least a 4" gap. A minimum 2" gap is recommended between cases on end-to-end installations. All minimum spacing requirements may increase if seismic restraints are used.

Building soffits must be set back at least 6" from the front of the case to allow access to electrical wiring on the top of the case.

INSTALLATION & OPERATION

Moving Cases

Various tools and equipment may be used to move cases, including, but not limited to, a forklift, a Johnson bar, a pallet jack, furniture rollers, casters, or a Rol-A-Lift. Be careful to avoid damaging the store flooring. Only certified forklift drivers should use forklifts to move the cases. The case should only be lifted off the floor as high as necessary for transport. The forklift should be driven slowly; avoid abrupt motions or bumps.

- Use the end frame to push/pull the case. For best results, push/pull lower on the end frame. **Do not push/pull on the mullions as this can cause the mullions to bend.**
- When using a Johnson bar, only contact the sheet metal of the bottom foamed panel. **Do not contact the bumper support or end panel. Be careful not to pierce the sheet metal with the corner of the Johnson bar.**
- When using a pallet jack or furniture rollers, only place them under the floor panels. **Do not place them under the bumper support or drain pipe as that will crush the components.**
- Cases have steel protective support plates under the end panels (not under insulated dividers) to protect them from Johnson bar damage.

Make sure that a forklift with the proper fork dimensions is available. **Forks must be 48" long, 1 1/2" to 1 3/4" thick, and no more than 4" wide to fit the bases.** Refer to the table below for instructions.

CASE MODELS	INSTRUCTIONS
2RVMC24	Forks must extend 20" to 24" under the case from either end
3RVMC24	Forks must extend 26" to 30" under the case from either end
4RVMC24	Forks must extend 39" to 43" under the case from either end
6RVMC24	Forks must extend 44" to 47" under the case from either end
2RVMC30	Forks must extend 26" to 30" under the case from either end
3RVMC30	Forks must extend 39" to 43" under the case from either end
4RVMC30	Forks must extend 44" to 47" under the case from either end
5RVMC30	Forks must extend 44" to 47" under the case from either end

OPTIONAL BASES

For low shipping height applications, such as 80" tall doorways, Zero Zone offers 1" bases or 1 3/4" bases.

- Cases with 1" bases will be shipped on a wooden pallet and are not forkliftable. The case can be removed from the pallet to slide it through the 80" doorway.
- The 1 3/4" bases are expandable to accommodate up to 1 3/4" thick forks (**See Figure 2**). To use a forklift on the expandable bases, raise the case with a Johnson bar and place wooden blocks under the case, allowing the base to expand enough for forks to be inserted.

FIGURE 2: Expandable Base

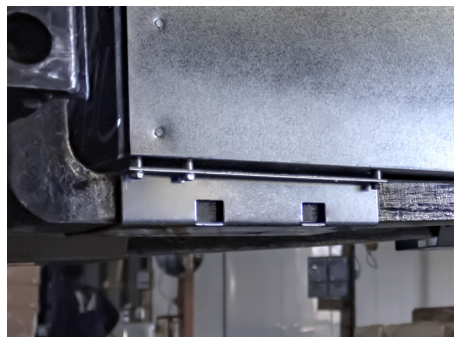

INSTALLATION & OPERATION

Cases with 1" or 1 3/4" bases will be set on hat channel rails or into nested bases (**See Figure 3**). The drain elbow will be shipped loose and must be installed using extra thick PVC cement after the case set in place.

Spacer blocks (also called filler blocks) are included in the end bases of 4-door, 5-door, and 6-door cases that use bases which are taller than 3 1/2". Spacer blocks limit the case's forward tilt while it is lifted by a forklift. Forks should be inserted above the spacer blocks (**See Figure 4**).

FIGURE 3: Nested Base



FIGURE 4: Spacer Block

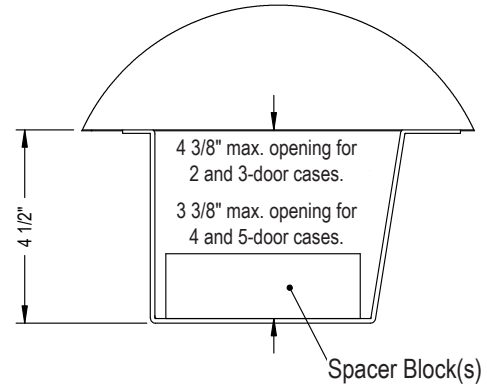

Leveling

Cases should be set level right to left to allow complete drainage of defrost and condensate water. Since a level floor area is seldom available, the following steps are recommended to ensure a level installation. If your case uses seismic restraints, specific instructions for attaching seismic restraints are included in your document package. Read and understand these instructions before assembling the lineup.

1. Measure off and mark on the floor the exact dimensions of the case lineup (**See Figure 5**). Refer to the fixture plan or floor plan.
2. Snap a chalk line at the locations for the front and back positions of the bases.
3. Mark locations of all joints, both front and back.
4. Using a laser level or transit, find the highest point along both base position lines. Using the high point as a reference, mark the difference directly on the floor to each base, both front and back (**See Figure 6**).

FIGURE 5: Measure and Mark Exact Case Outline

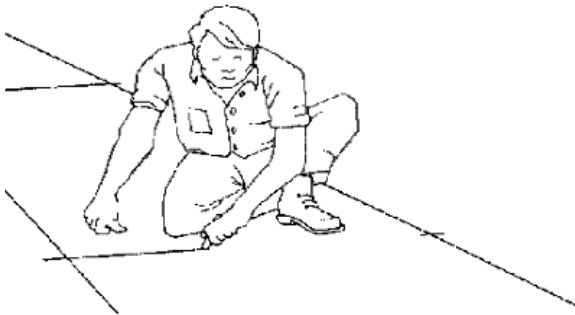
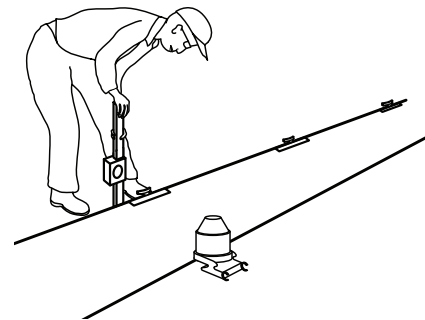

FIGURE 6: Mark Floor Level Difference



5. If your case uses optional hat channel rails to raise the case height, place shims **under** the hat channel rails (**See Figure 7 on page 7**). On 3 and 4-door cases, the center bases are not aligned, so the hat channel rails must be angled slightly to support the bases (**See Figure 10 through Figure 13 starting on Page 8**).
6. Place enough shims under each base or optional hat channel rail to equal the highest point. Shims should not extend beyond the front case bases or they will interfere with installing trim. The shims should be oriented to sit under the front and rear bends of each base. Tape all shims in place (**See Figure 8 and Figure 9 on page 7**).

INSTALLATION & OPERATION

FIGURE 7: Hat Channel Rail Orientation

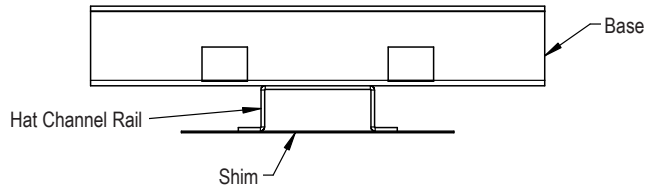

Position hat channel rails with tape up. Place shims perpendicularly under the hat channel rails.

- 2-door cases get 2 hat channel rails.
- 3 and 4-door cases get 3 hat channel rails. Do not position under the drain hub.
- 5-door cases get 4 hat channel rails.

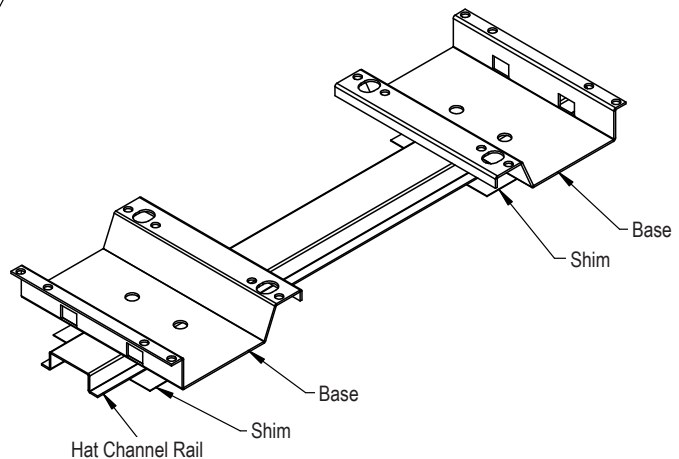

FIGURE 8: Tape Shims on the Floor Under Each Base or Hat Channel Rail

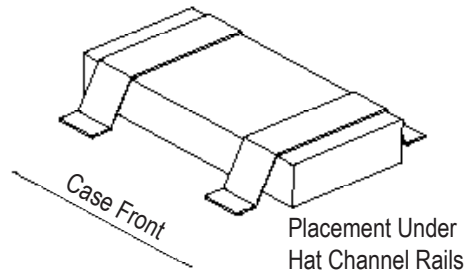
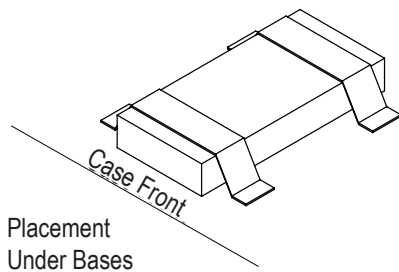
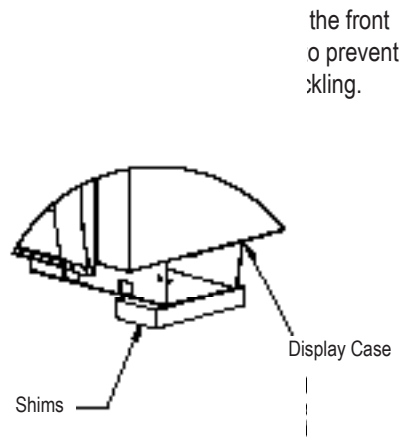
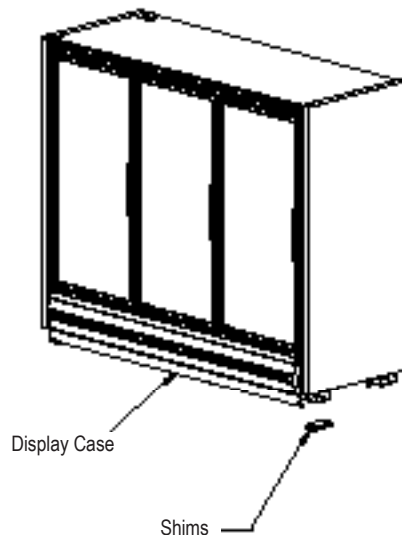

FIGURE 9: Shims Under Bases (Without Hat Channel Rails)



INSTALLATION & OPERATION

FIGURE 10: RVMC30 Base Locations

Drawings are top views with bases shown under the case. The front of the case is toward the bottom of the page.
Case length does not include end panels (2 1/2" wide each).

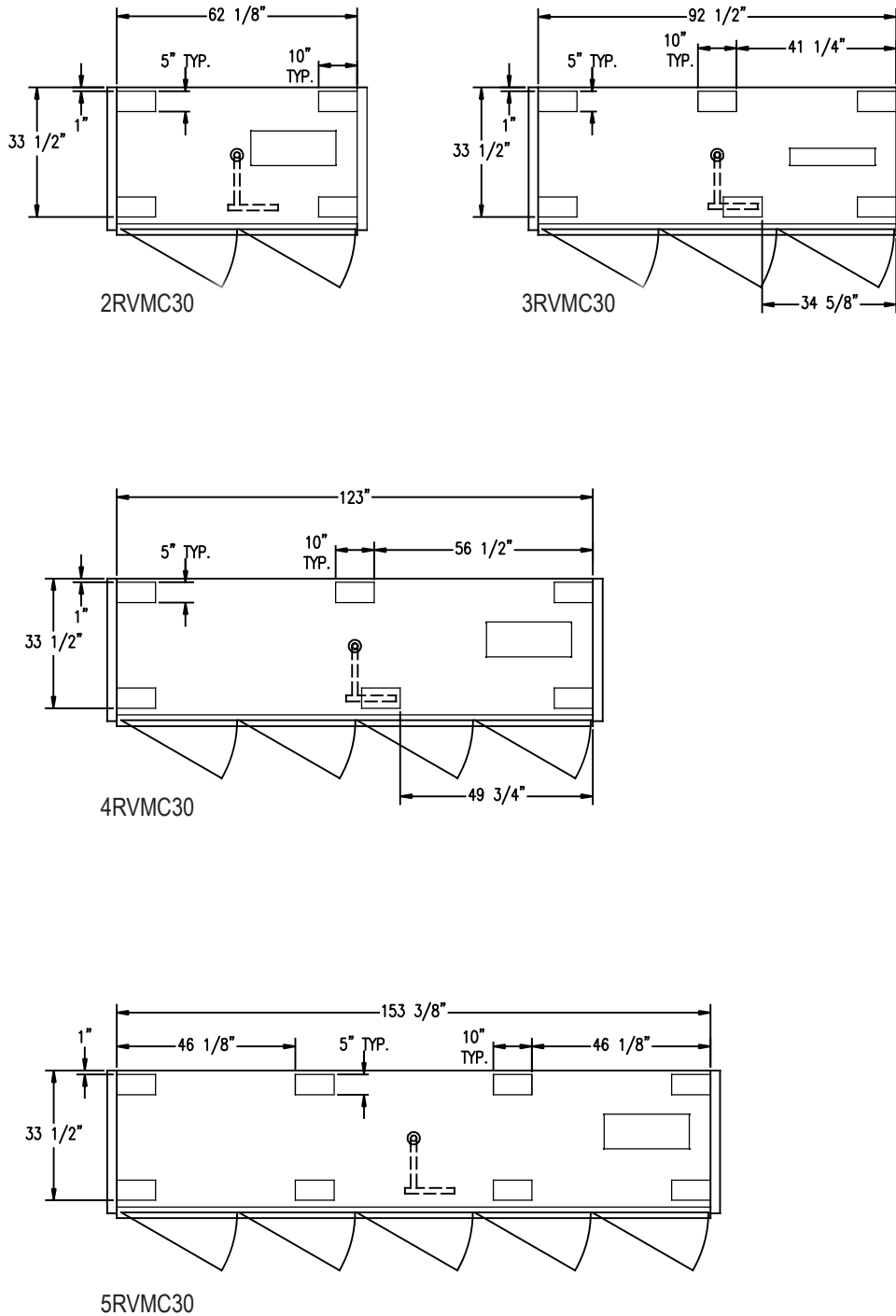

INSTALLATION & OPERATION

FIGURE 11: RVMC24 Base Locations

Drawings are top views with bases shown under the case. The front of the case is toward the bottom of the page.
Case length does not include end panels (1 1/2" wide each).

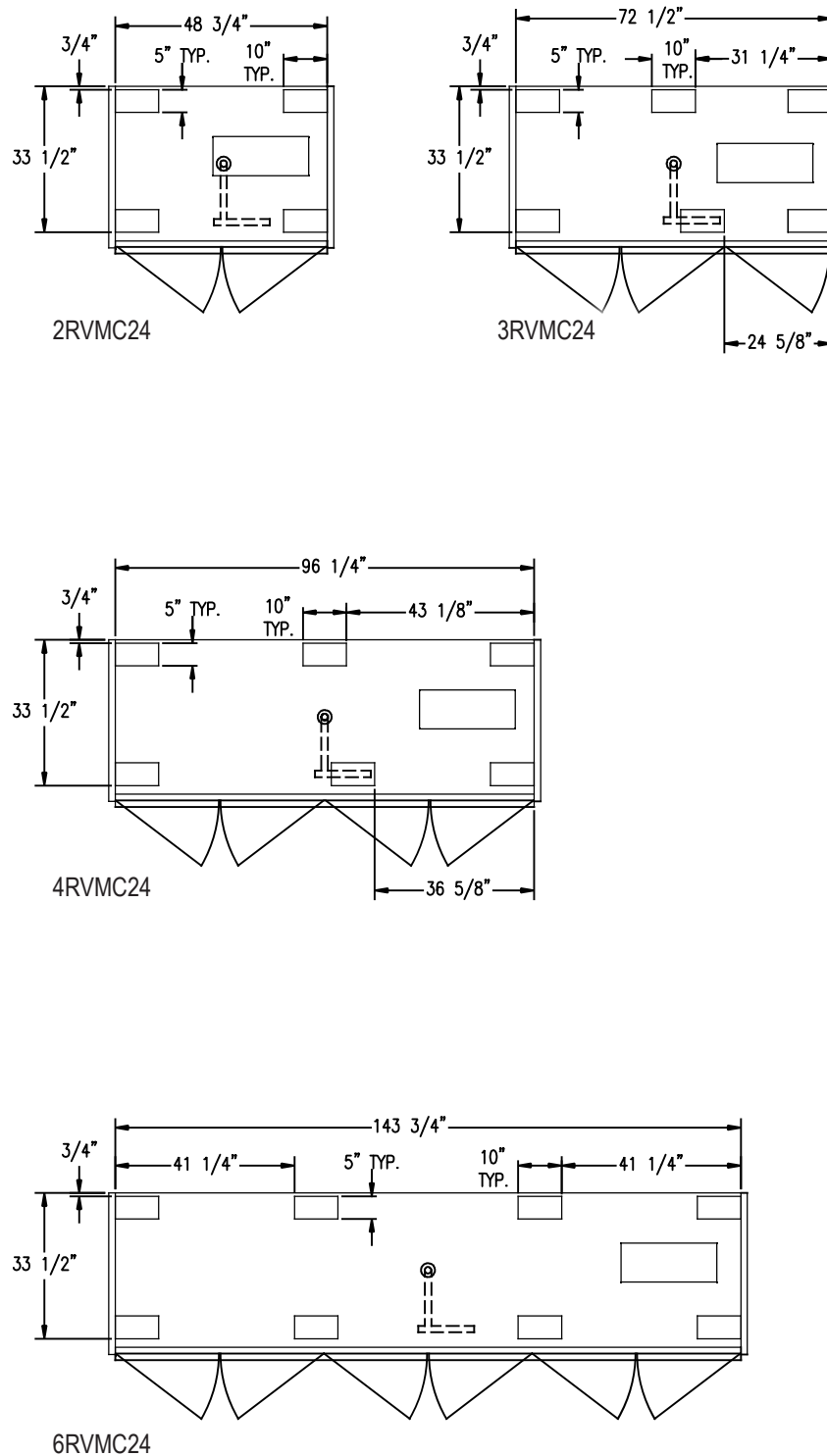

INSTALLATION & OPERATION

FIGURE 12: RVMC30D (Deep Case) Base Locations

Drawings are top views with bases shown under the case. The front of the case is toward the bottom of the page.
Case length does not include end panels (2 1/2" wide each).

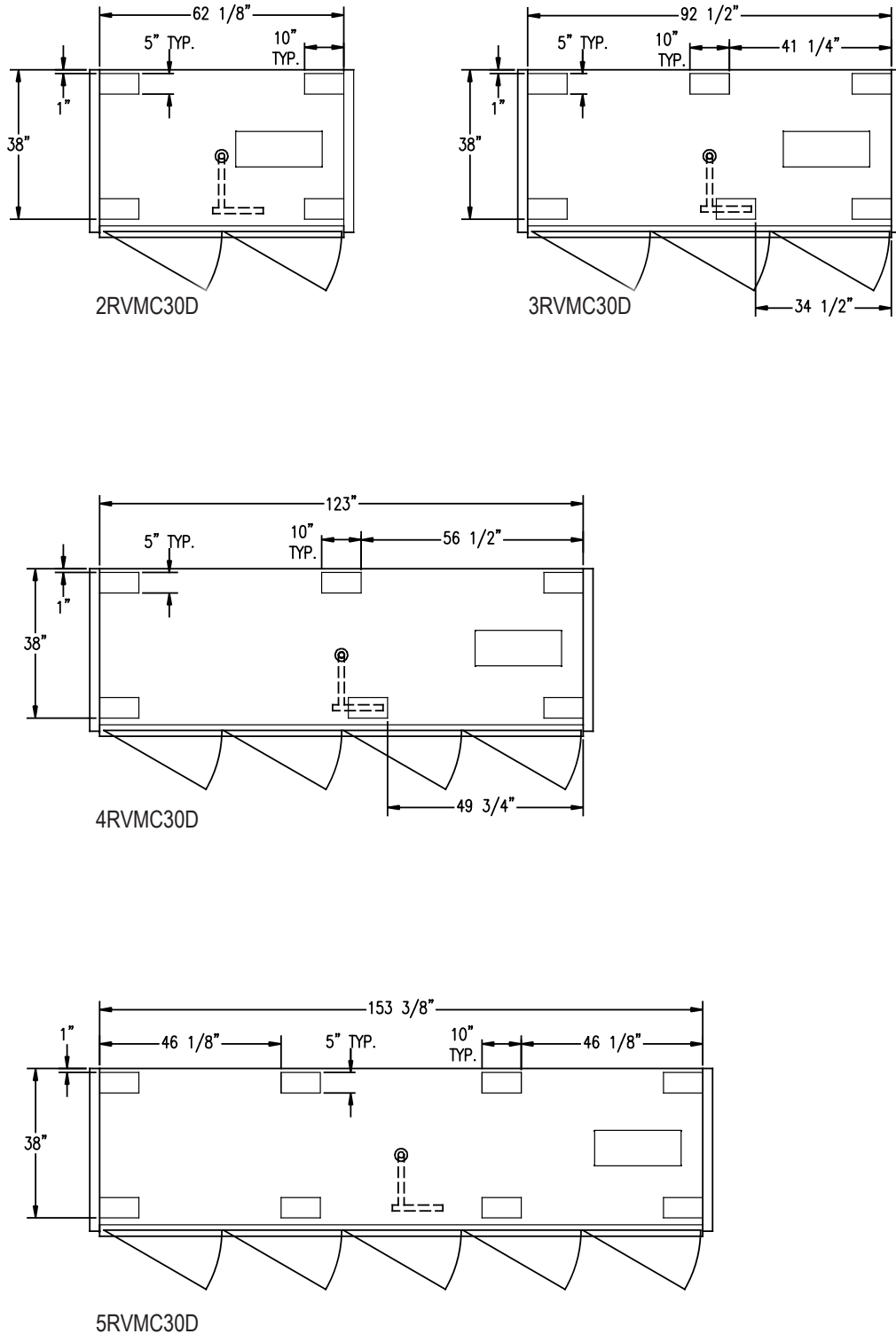

INSTALLATION & OPERATION

FIGURE 13: RVMC24D (Deep Case) Base Locations

Drawings are top views with bases shown under the case. The front of the case is toward the bottom of the page. Case length does not include end panels (1 1/2" wide each).

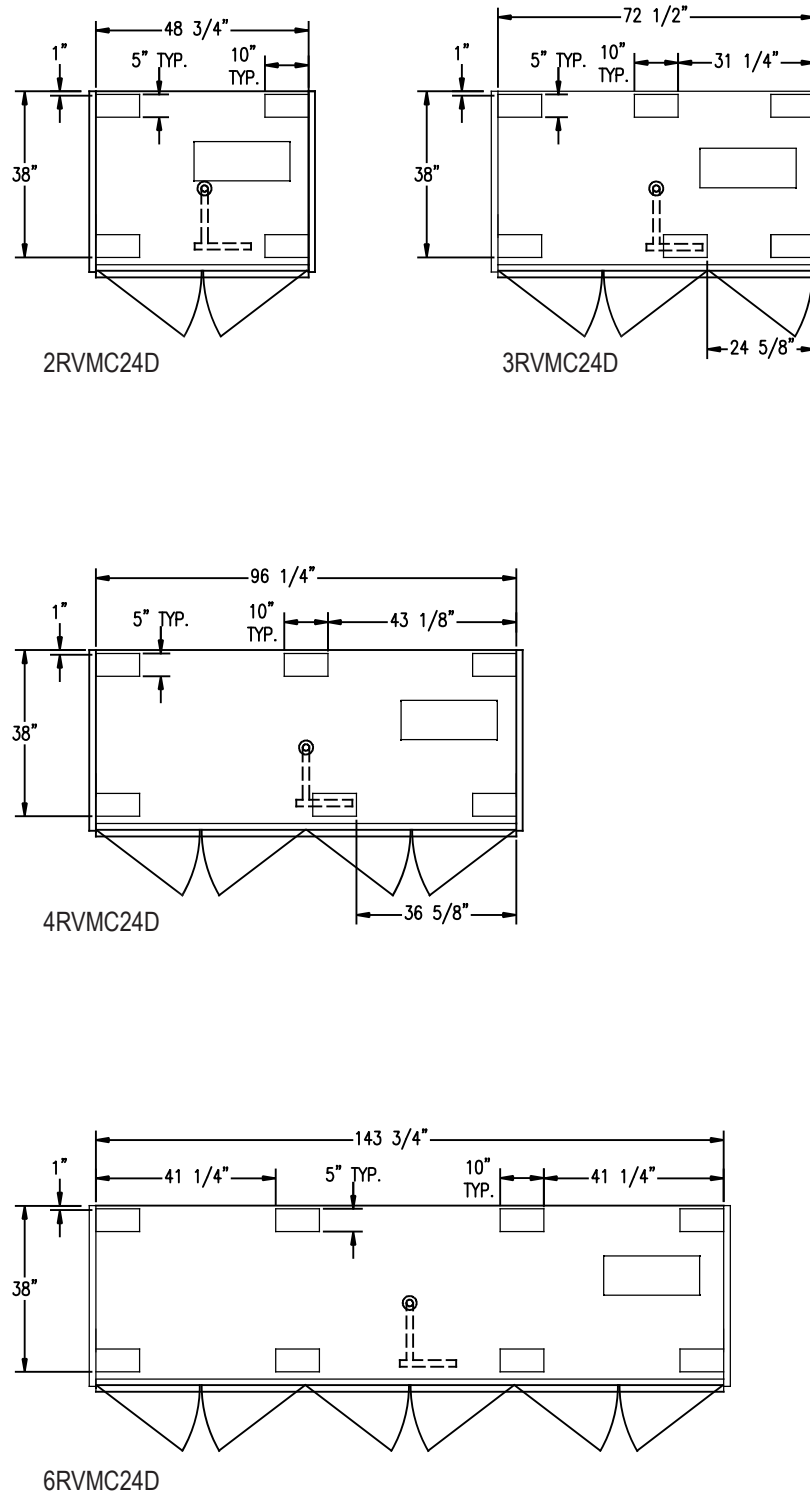

INSTALLATION & OPERATION

7. The case is designed with minimal gaps between adjacent doors to provide a clean appearance. To maintain even, consistent gaps and proper door operation, the case must be leveled front-to-back and side-to-side. Ensure that the case is set square to within 1/8" (See **Figure 15**). After the case is set, use at least a 48" level to ensure the case is level. Add additional shims as needed under specific bases. This will reduce door sag/sawtooth (See "Door Leveling" on page 11).

FIGURE 15: Case Squareness

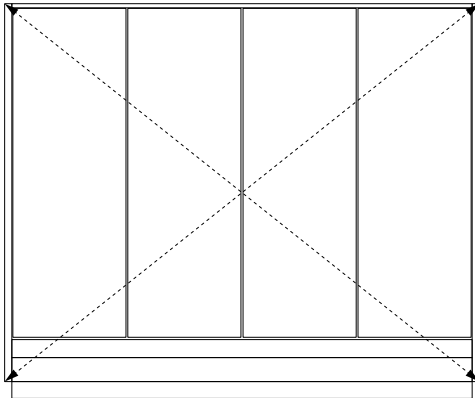

1. Measure squareness from top right corner of the case to the bottom left corner of the case.
2. Measure again from the top left corner of the case to the bottom right corner of the case.
3. Measurements should be equal. Difference should be no more than 1/8".

8. Standard depth and Deep cases should be set with a slight backward tilt to offset the forward lean of a fully loaded case. We recommend an additional 3/8" of shims be installed under the front bases after the case is leveled (See **Figure 14**). **Note: Do not add extra shims under Ultra Narrow cases.**

FIGURE 14: Tilt Back

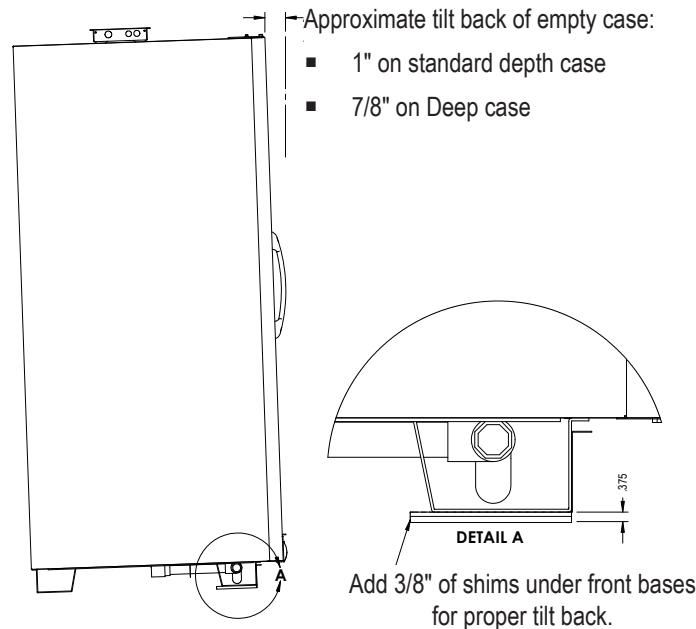

INSTALLATION & OPERATION

9. When joining a Crystal™ freezer to a Crystal™ cooler, both cases should be tilted back with an additional 3/16" of shims under the front bases after the case is leveled. When joining multiple freezers and coolers in a lineup, the tilt back on the coolers should gradually increase while working away from the cooler/freezer joint until the last case has an additional 3/8" of shims under the front base and the tilt back on the freezers should gradually decrease to no additional shims while working away from the cooler/freezer joint (See Figure 16).

FIGURE 16: Cooler to Freezer Leveling

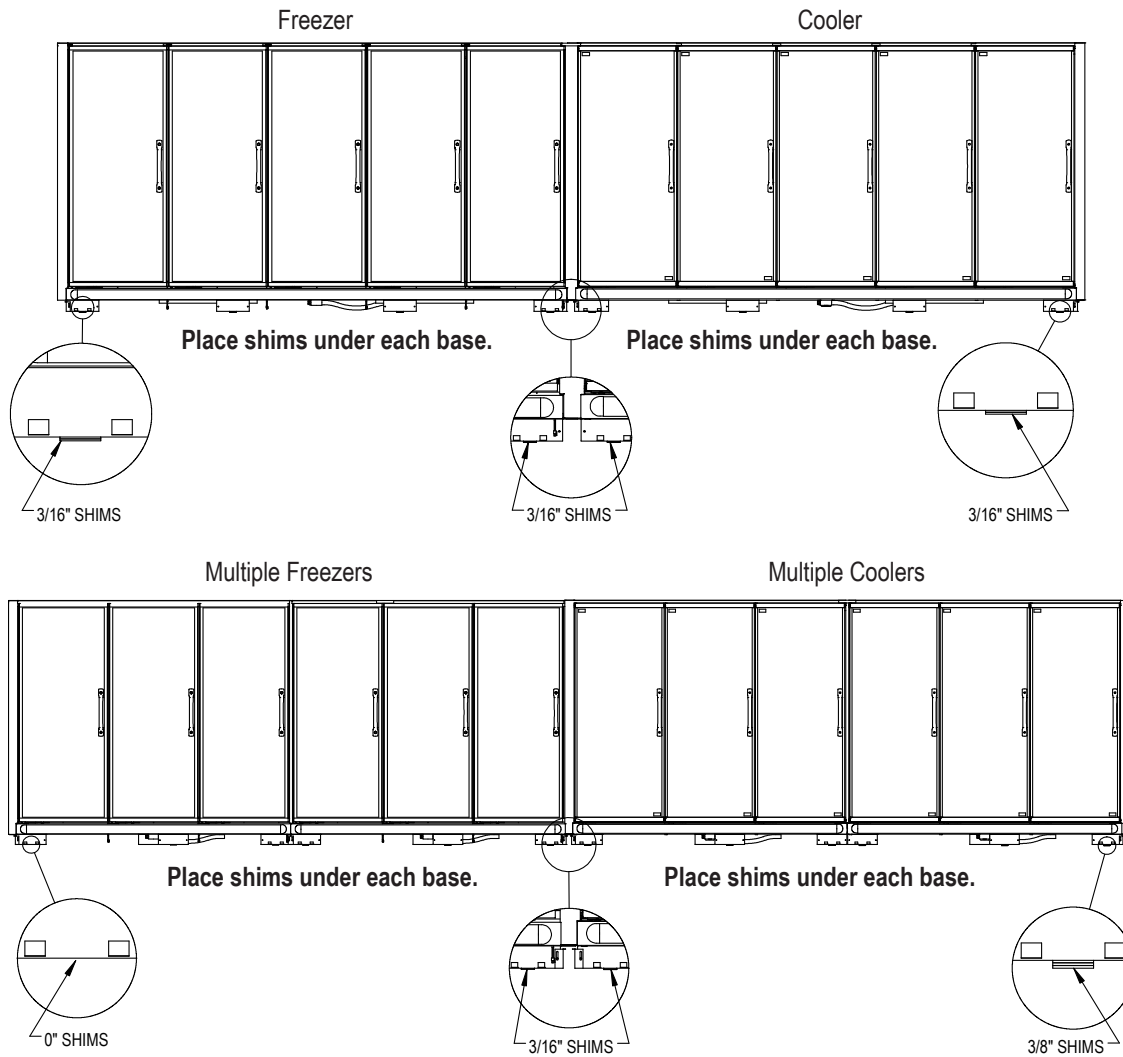

10. Place additional support shims under any bases or hat channel rails with gaps taller than one shim. **Do not place shims between bases and hat channel rails. Total height of shims should be less than 3/4".**

Lineup Assembly

Zero Zone display cases have been designed for continuous display so that multiple cases may be joined together to create a lineup of any desired length. The lineup will be ready for assembly after removing the packaging material.

A case lineup must be properly aligned, which starts with properly leveling the case (See "Leveling" on page 6). It is crucial to use a laser level to measure the high points in the floor and properly shim each base location.

INSTALLATION & OPERATION

The bottom of the end panels are protected by steel support plates, which must be unbolted and removed before the lineup is set. There are bolts that go up through the support plates into the underside of the foamed floor.

A 1" wide trim piece seals the vertical gap between cases. It is shipped on the left end of a case with an open end. The next case in the lineup will slide up to the trim piece so that the door seals against the trim piece. Remove the screws that held it during shipment, and use the provided hardware to join the trim to the case using the top and bottom joining holes in the extrusion (See Figure 17).

A case must be prepared with Butyl caulk before setting the next case in the lineup. Case caulking instructions and caulk are shipped with every case (See Figure 18 on page 15).

Move the next case into position and bolt it to the first case using the 4 joining bolts that are provided. Begin tightening the bolts at the top rear, working down the back of the case and up the front, making sure that the seams are flush. **Do not pull cases together using joining bolts.** (See Figure 19 on page 16).

An insulated divider is used to join 2 different case models or 2 different temperature cases. The divider is typically factory-installed to one of the cases. There are 2 types of insulated dividers:

1. Between a Crystal™ cooler and a different case: The insulated divider has a panel on each side with nut inserts in the panels; each side is bolted to the respective end frames. **Do not pull cases together using joining bolts.**
2. Between 2 Crystal™ coolers: The insulated divider uses a thru-bolt design. The divider is attached to one of the cases using short bolts for shipping. When the cases are installed, the short bolts are removed and longer joining bolts are installed to bolt the cases together. **Do not pull cases together using joining bolts.** (See Figure 20 on page 16).

The interior case seams must be sealed using silicone sealant for NSF compliance (See Figure 21 on page 17). Do not allow Butyl caulk and silicone sealant to contact one another as this may affect adhesion or color of each.

FIGURE 17: Vertical Joint Trim Installation

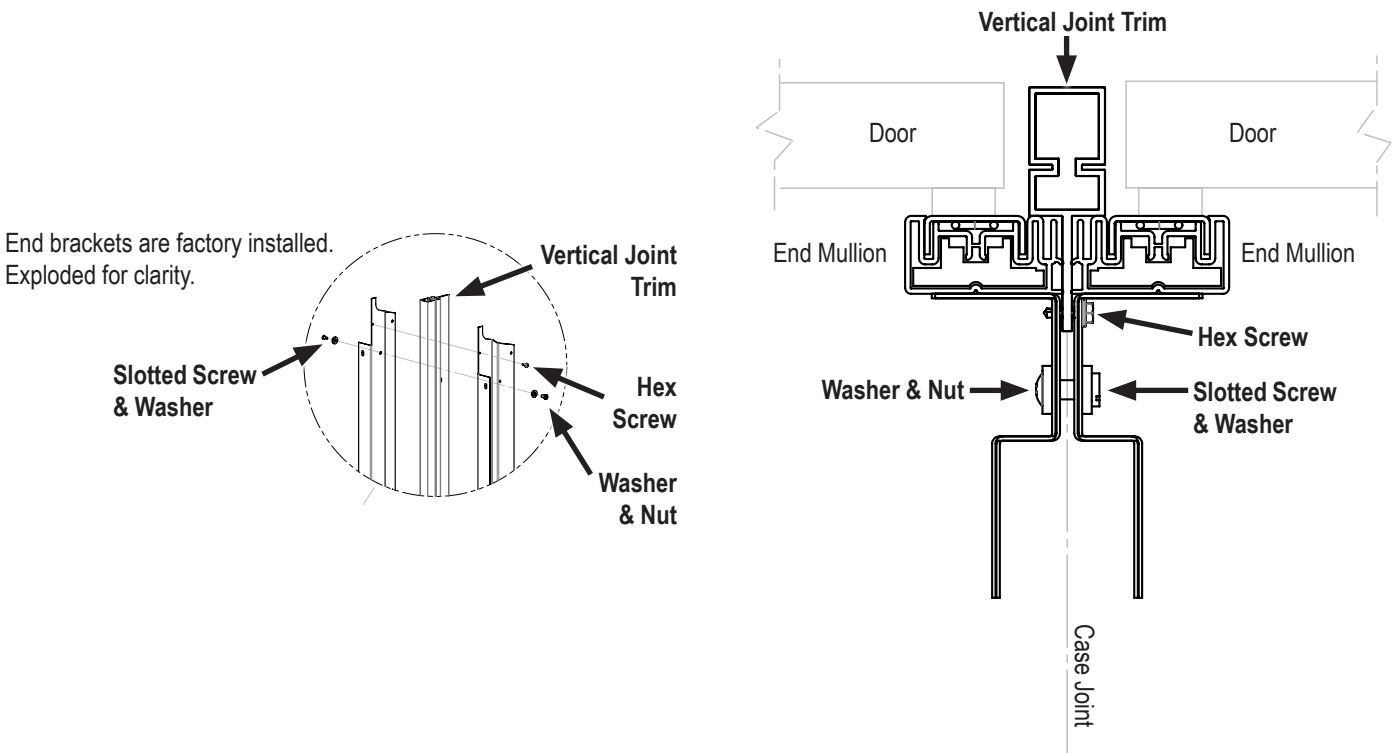

Apply caulk between joints. Attach vertical joint trim using the hex screws. Join cases using joint hardware.

INSTALLATION & OPERATION

Before joining the cases, remove all packaging material on the display case, including any spacer blocks inside the bases. Repeat caulking between each case in the lineup.

FIGURE 18: Case Joint Caulking (Butyl*)

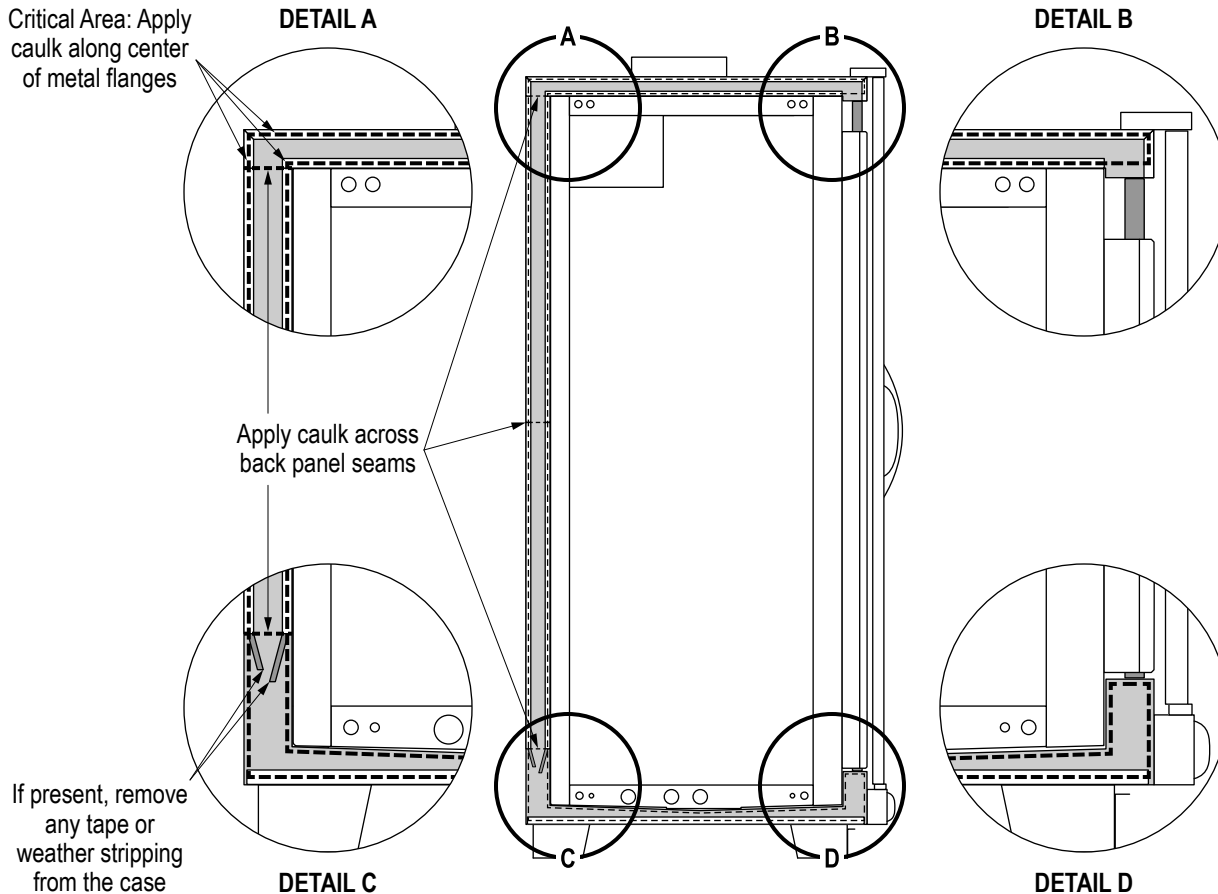

IT IS CRITICAL TO FOLLOW THIS PROCEDURE TO ENSURE CASES ARE PROPERLY SEALED.

SURFACES TO BE CAULKED MUST BE CLEAN, DRY, FREE OF TAPE/ADHESIVE, AND FREE OF FROST (ABOVE 40°F).

Note: Apply Butyl caulk to only one case—not both cases. The caulk will spread out when the cases are pushed together, and excessive caulk may squeeze out of the joint. Wipe away any caulk that squeezes out. Butyl caulk will not mix with silicone sealant (used for NSF sealing), which will affect adhesion of both.

1. Remove all shipping material. This includes packaging and packing tape.
2. Apply 1/2" thick beads of Butyl caulk* along the ceiling, rear wall, and bottom of the case where indicated by the dashed lines in the drawing. Caulk must be continuous with no gaps. Always apply 2 beads where specified. Caulk must be applied around a plexiglass divider and not onto the divider itself, if applicable.
3. After cases are joined and tightened, caulk the top and back exterior seams, if accessible, to ensure a tight seal.
4. **See Figure 21 on page 17** for information about NSF compliance sealing with silicone sealant.

*DO NOT APPLY BUTYL CAULK ON SEAFOOD OR BAKERY CASES. Butyl caulk never cures and emits vapors that affect seafood and bakery products. Recommended alternative caulk: Polyurethane-based (full curing, durable, moisture-activated) or silicone-based (full curing).

INSTALLATION & OPERATION

FIGURE 19: Case Joining Hardware
Only showing end frames of cases

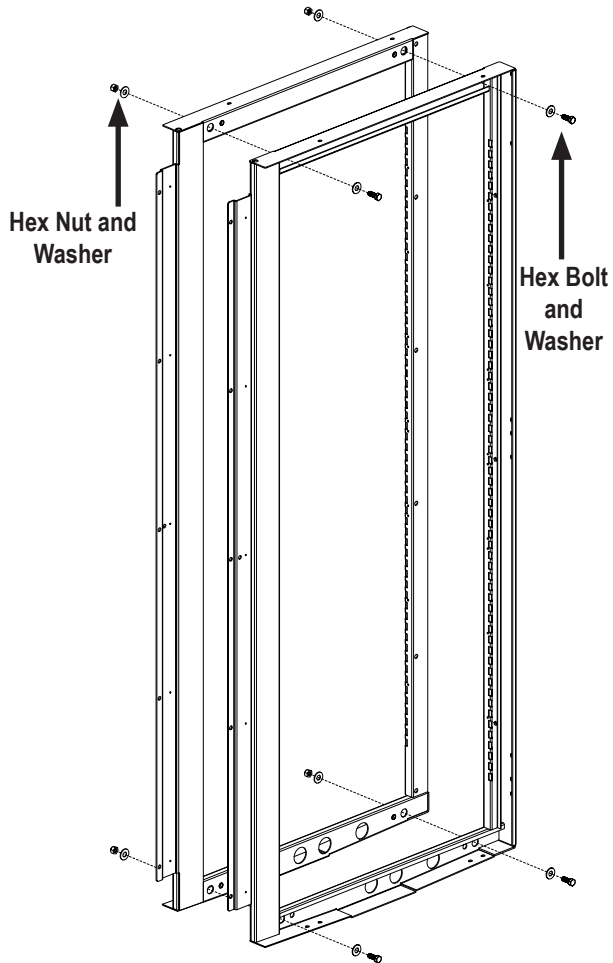

3/8"-16 x 1" hex bolts (4), 3/8"-16 hex nuts (4), 3/8" washers (8)

FIGURE 20: Case Joining Hardware with Insulated Divider
Only showing end frames of cases

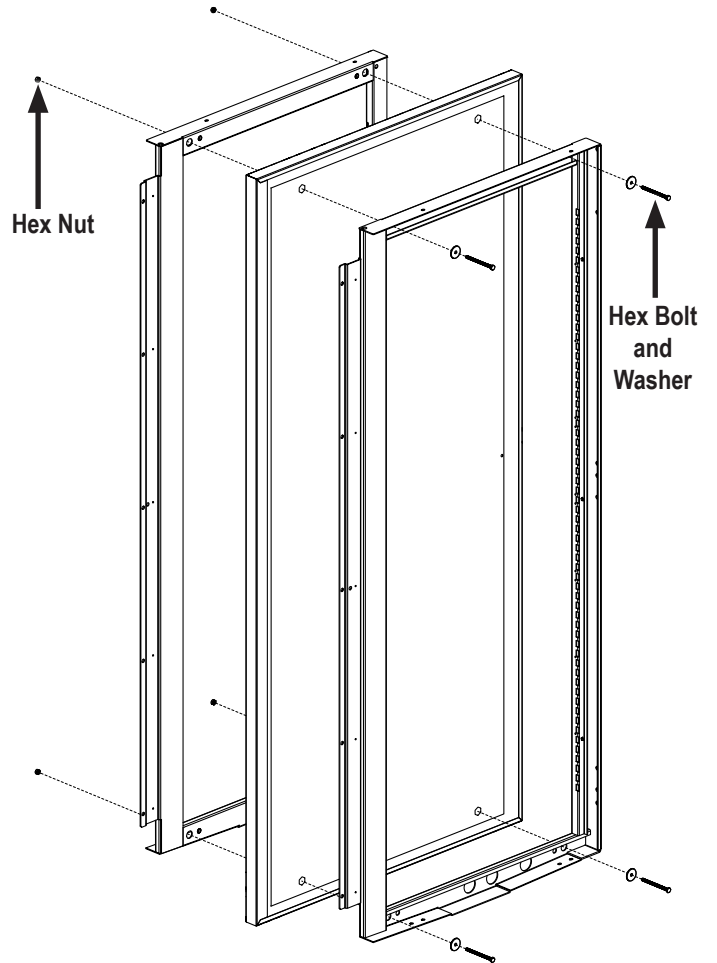

1/4"-20 x 3 1/2" hex bolts (4), 1/4"-20 hex nuts (4), 1 1/4" washers (4)

INSTALLATION & OPERATION

FIGURE 21: NSF Compliance Sealing (Silicone)

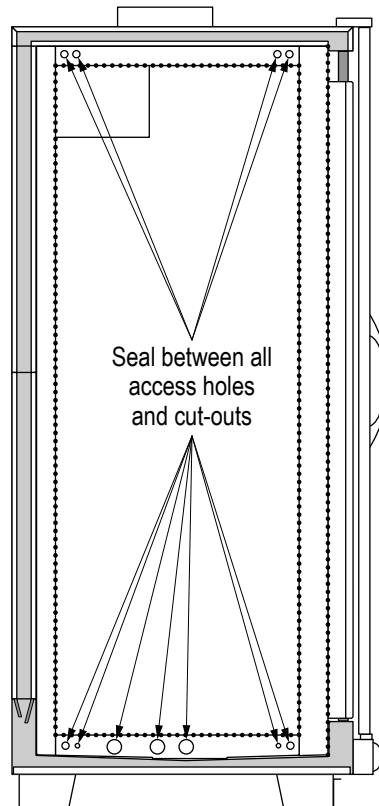

THIS PROCEDURE MUST BE FOLLOWED FOR NSF COMPLIANCE.

SURFACES TO BE SEALED MUST BE CLEAN, DRY, FREE OF BUTYL CAULK, AND FREE OF FROST (ABOVE 40°F).

Note: Cases must be properly caulked and joined before NSF sealing. Wipe away any Butyl caulk that squeezes out of the case joint. Butyl caulk and silicone sealant will not mix, which affects the adhesion of both. See Figure 18 on page 15.

1. Apply silicone-based sealant in small, continuous beads where indicated by the dotted lines in the drawing. Do not thin or feather, as that will affect adhesion.
2. Sealant must be added between cases at case joints, between a case and an end panel, and between all access holes and cut-outs in the case end frame.

INSTALLATION & OPERATION

Ultra Narrow Case Anchoing

The Ultra Narrow case (RVMC24UN) must be anchored to either another case or a wall to ensure the case will not tip forward. The Back-to-Back Ultra Narrow (RVMC24BBUN) does not require anchoring. It may be used as the anchor for the Ultra Narrow case.

Two case-to-wall support brackets will be provided when anchoring the Ultra Narrow to a wall (See Figure 22). Two case-to-case support brackets will be provided when anchoring the Ultra Narrow to another case. The Ultra Narrow case must be set 3" away from the other case for proper ventilation, so a provided trim piece must be field-installed to cover the gap (See Figure 23).

FIGURE 22: Anchoring Ultra Narrow to a Wall

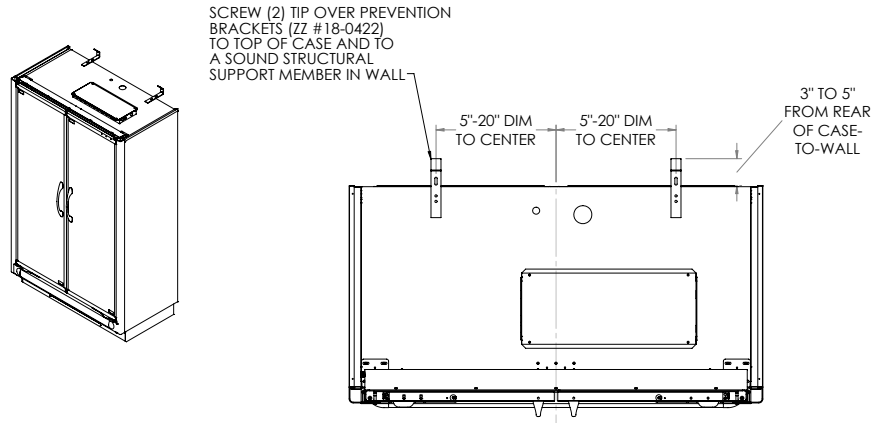
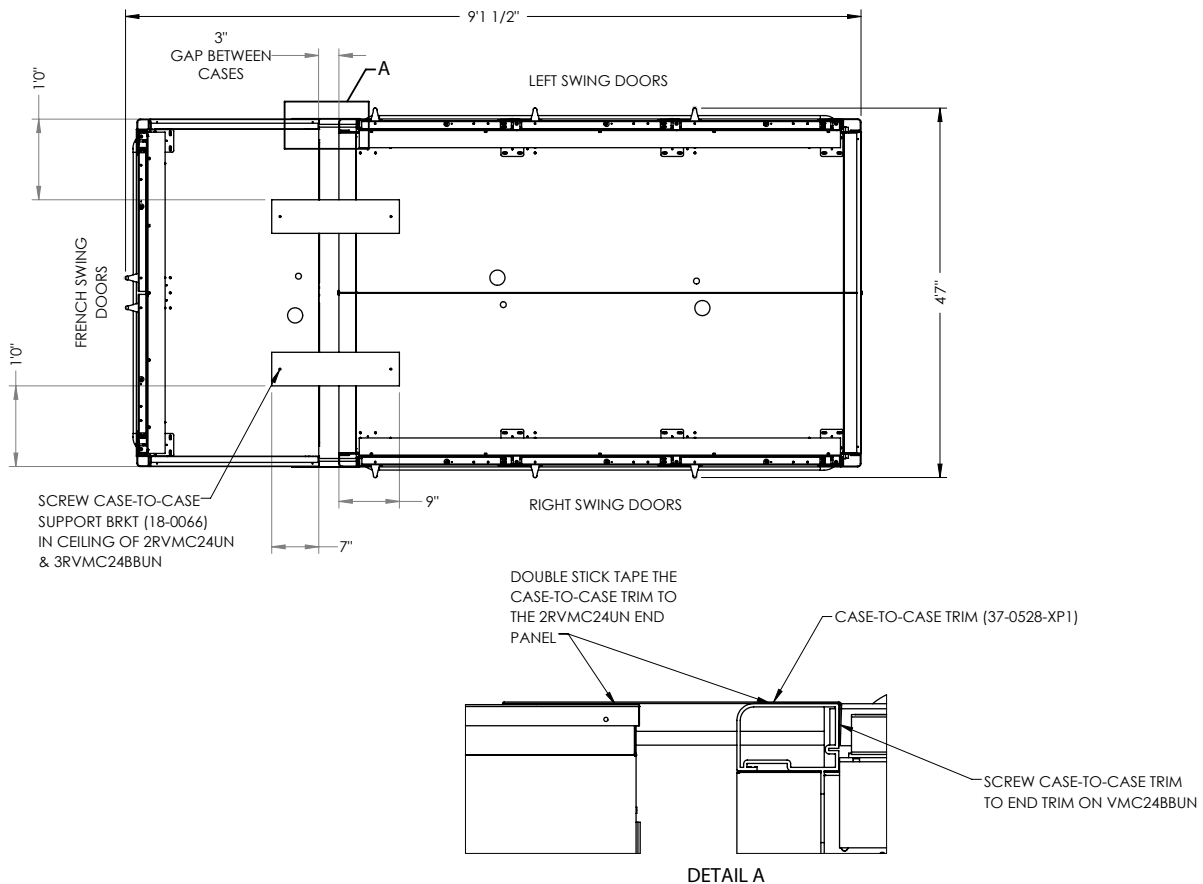

FIGURE 23: Anchoring Ultra Narrow to Another Case



INSTALLATION & OPERATION

Door Leveling (Door Sag/Sawtooth)

Doors must be leveled before the bumper and kickplate are installed.

For same-swing doors, door-to-door gaps should be 3/8". For French-swing doors, door-to-door gaps should be 7/16" at the handle side and 3/8" at the hinge side. To set the proper gaps, loosen screws holding the top or bottom door mounting plates, then shift the door.

BOTTOM MOUNTING PLATE

To move the bottom mounting plate, the center locking screw (located behind the bumper) must be loosened.

1. To remove the bumper, use a flathead screwdriver to pry it up from the bottom. Lift the edge, and then slide the screwdriver down the entire length of the bumper to loosen it. Once the bottom edge is disconnected, use a hammer to tap the screwdriver upwards and disengage the bumper from the upper track. Remove the bumper.
2. Loosen the center locking screw by 2 turns, accessed through the hole in the bumper support plate (See Figure 24). This will allow the bottom mounting plate to shift. **Do not remove the center locking screw.**
3. Tap the door's aluminum extrusion with a rubber mallet to shift the door. Once the door is in position, retighten the center locking screw.

TOP MOUNTING PLATE

1. To access the top mounting plate, remove the top trim piece. This will require a Phillips bit and a 1/4" hex screw bit.
2. Loosen all 3 screws that secure the slotted plate by 2 turns (See Figure 25). **Do not remove the screws.**
3. Tap the door's aluminum extrusion with a rubber mallet to shift the door. Once the door is in position, retighten all screws.

Drain

The drain is located at the center of the case in the floor pan. The 1" PVC drain outlet is located at the center front of the case behind the kickplate.

The drain trap will run through the bases. There is no room in front of the base for the drain trap because the kickplate installs directly to the front of the bases.

The tee, drain trap, and plug are shipped loose with the case. Install the tee to the lateral. **The frontward bend of the drain lateral bracket will hold the tee level (See Figure 26).** Install the drain trap to the tee in the direction of the floor drain. Plug the open end of the tee using the clean-out plug supplied with the drain trap kit. **The drain trap should be primed with water after installation.**

Complete piping from the drain trap to the floor drain. The piping must be pitched away from the drain trap enough to ensure proper drainage. Consult local codes for minimum requirements.

When cases have 1" bases, they are shipped on wooden skids or pallets, and the drain lateral and bracket must be shipped loose so they will not be crushed during shipment. Run the lateral from the floor drain. Fasten the bracket to the floor behind the forklift plates with the lateral through it. Continue with the rest of the drain installation.

FIGURE 24: Center Locking Screw

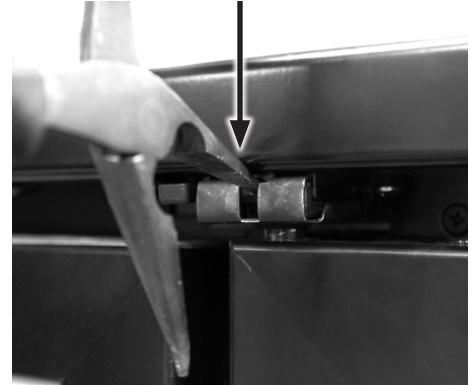

FIGURE 25: Top Mounting Plate

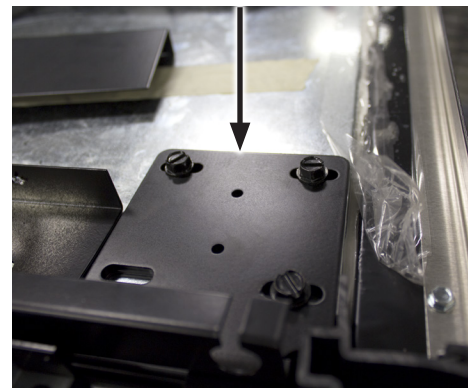
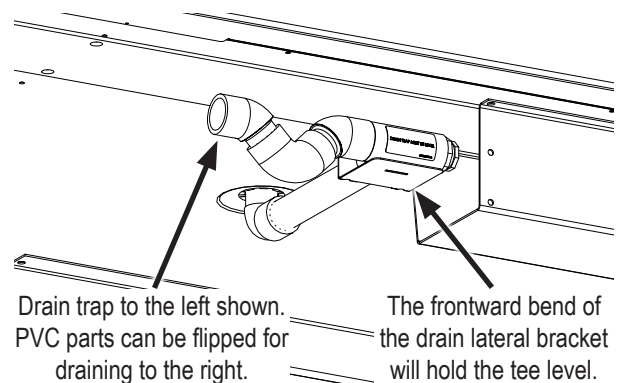

FIGURE 26: Drain Installation



INSTALLATION & OPERATION

Condensate Removal System

Zero Zone remote cases can be equipped with a condensate removal system. The system uses a drain pan with pump located behind the kickplate and a condensate evaporation pan mounted on the top of the case.

Condensate water and any liquid spilled in the case will drain into the drain pan. The pump is equipped with a float that turns the pump on when there is a sufficient liquid level. Liquid is pumped through a plastic hose through a check valve and into the condensate evaporation pan. The evaporation pan is equipped with a heater and a float switch to turn on when the heater is submerged in liquid. When the heater is energized, the evaporation pan will be extremely hot and should not be touched. The pump and evaporation pan should be cleaned regularly. Any spilled product, other than water, should be cleaned to prevent odors.

Kickplates

Each case is shipped with a front kickplate. Cases with end panels are shipped with 1 side kickplate per end panel. Cases that join together are shipped with a kickplate splice.

Front and side kickplates are attached to the case bases using Tinnerman clips. Position the front kickplate so the flange is on top and facing outward. The screw (supplied) goes through the kickplate and into the Tinnerman clip (See Figure 27).

There is a natural gap between the top of the kickplate and the underside of the Crystal Merchandiser® that allows airflow of 50 CFM per door. If more airflow is required, contact the factory to order optional louvered kickplates (provides 150 CFM per door).

Bumper

Cases are supplied with a 3" protective bumper shipped loose on top of each case. Each case has its own bumper assembly, including end caps. The steel bumper support and snap track are factory-installed on the front of the case. The bumper may need trimming before snapping it onto the snap track.

Door leveling must be completed before attaching the bumper (See "Door Leveling (Door Sag/Sawtooth)" on page 19).

Top Trim

Top trim is factory-installed, and it hides the door hardware located on the top exterior of the case. Joint splices are shipped loose and must be field-installed at the upper case joints.

CoolView® Doors

COOLARC™ DOOR HANDLES

CoolView® Ultra™ doors use the CoolArc™ door handle. The CoolArc™ door handle is attached to the glass surface of the door by an industrial-grade adhesive.

FIGURE 27: Kickplate Installation

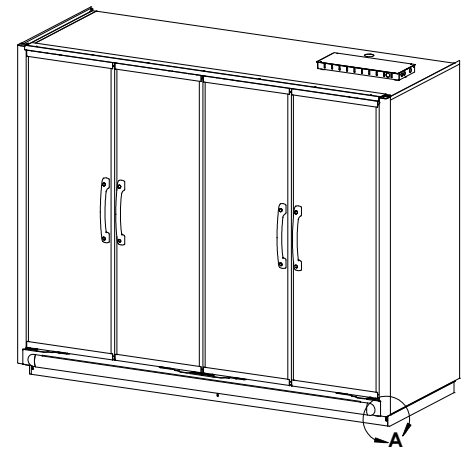

1. Install Tinnerman clip at each base.
2. Position side kickplate.
3. Position front kickplate with top flange facing outward.
4. Insert fasteners to secure the front and side kickplates to the Tinnerman clips.

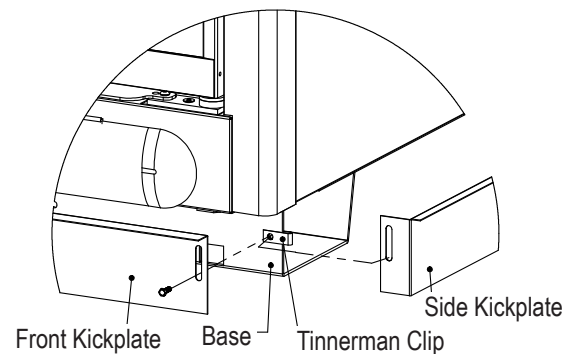

DETAIL A (EXPLODED)

INSTALLATION & OPERATION

HOLD-OPEN BRACKET

CoolView® doors are self-closing, and closing tension increases as the door opens wider. The hold-open bracket keeps the door open when engaged, which is useful for stocking shelves or case maintenance. To engage the hold-open bracket, open the door to at least 90° until it clicks. Closing the door to about 80° will release tension on the door, and it will self close again.

The hold-open bracket is located on the bottom of the door on Crystal™ cases (See Figure 28).

DOOR GASKET

Upper and lower horizontal magnetized gaskets run the length of each case. The gaskets mate up to steel plates installed at the top and bottom of each door. A vertical gasket runs along the hinge-side of each door. The gasket seals against the handle-side of each adjacent door. At the end of each case, another gasket is placed on the handle-side of the door and is used to seal against the side of the case (instead of an adjacent door). French door cases include a sweeper gasket on the handle-side of each door.

DOOR CLOSER / ADJUSTING DOOR TENSION

The door closer is a spring cartridge that automatically closes the door. It is located on the bottom of the hinge side of the door. A square pin inside the door closer fits into a square opening on the door, transferring the spring tension to the door. This means that the square pin must be aligned with the square opening when installing a door. An adjustment screw on the front can be used to increase or decrease tension.

1. Open the door to observe current door tension. A properly tensioned door will close itself gently and not swing open.
2. Use a flathead screwdriver to turn the door tension screw (See Figure 29). **Do not use power tools; a screwdriver allows for more control.**
3. To increase tension, hold the door open 2 inches and turn the screw counter-clockwise until the door begins to close. Once it closes, increase tension by 2 more turns.
4. To decrease tension, turn the screw clockwise.

The screws holding the door closer are secured with removable threadlocker gel; extra force will be necessary to remove them.

REMOVING A DOOR

1. Remove the top case trim that covers the door hinges.
2. Turn door tension screw clockwise until door does not close on its own. This removes tension between the door and torque adjuster.
3. Disconnect the hold-open bracket from the bottom of the door (See Figure 28).
4. Remove shoulder bolt and bushing on the top of the hinge side of the door (See Figure 30). Only remove the bolt holding the door; do not remove the bolts attached to the case.
5. Pull the top corner of the door away from the case. **The door is heavy. Be prepared to hold the weight of the door.**
6. Lift the door up and clear of the torque adjuster and set down carefully. **For safety, do not lift the door by the handle.**

FIGURE 28: Hold-Open Bracket



FIGURE 29: Door Tension Screw



FIGURE 30: Door Shoulder Bolt



INSTALLATION & OPERATION

INSTALLING A DOOR

1. Lift the door and set it in the door closer. Line up the door so the square hole in the door sets into the square rod of the door closer. **The door is heavy. For safety, lift the door by the rails; do not lift by the handle.**
2. Lean the door into position against the case. Install the washer between the mounting plate and the door, and install the bushing and shoulder bolt above the mounting plate and into the door (See Figure). **You may need to get on a ladder to install the bolt and bushing. Be careful while doing this because the door will not be secured in place.**
3. Attach the hold-open bracket between the bottom of the door and the bottom of the case (See Figure 28 on page 21).
4. Turn the door tension screw counter-clockwise until the door gently closes itself (See "Door Closer / Adjusting Door Tension" on page 21).
5. Properly level the door to eliminate sag/sawtooth (See "Door Leveling (Door Sag/Sawtooth)" on page 19).
6. Reinstall the top trim piece and electrical raceway cover on top of the case.

Rear Load Cases

Rear Load cases are shipped with the rear sliding doors removed and shipped loose with the case. To maintain proper temperature, the Rear Load case must be positioned in the opening of a walk-in cooler. Before attaching the cases to the walk-in, measure the diagonal opening of the Rear Load case to ensure a square case installation. If the diagonal measurements are not within 1/8", the case must be re-leveled. After the cases are set, install the doors into the opening by inserting the top of the door into the upper track and then sliding the bottom of the door into the lower track.

Rear Load cases may be ordered with an optional insulated close-off for applications where a walk-in cooler does not have a curb along the floor (See Figure 31). After the case is set, the close-off must be installed to the bottom rear of the display case. It protects the display case from potential damage if a pallet of food or beverages is smashed into the back of the display case. It also prevents warm air from entering the walk-in cooler and prevents water from flowing underneath the display case.

FIGURE 31: Rear Load Insulated Close-Off

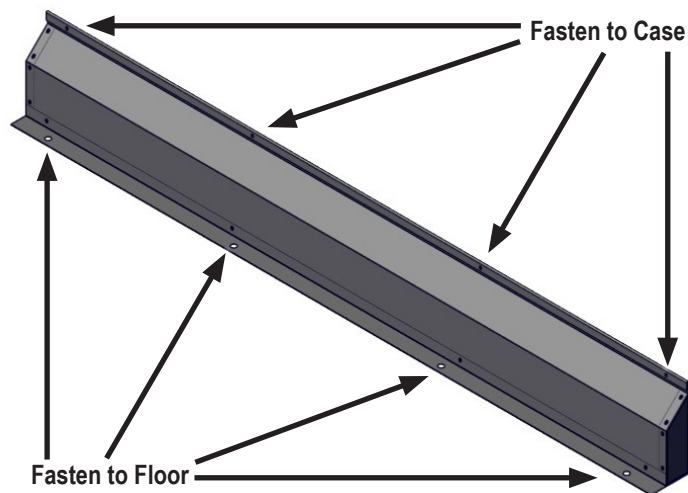

INSTALLATION & OPERATION

Shelves & Stocking Product

Shelf location may be adjusted in 1" vertical increments in any position for best display advantage. Make sure the shelf brackets are securely seated before placing any product on the shelf. The standard shelves may be tilted down at a 10° angle. Optional shelf assemblies are available that may be tilted at 5°, 10°, or 15° angle.

The case may be stocked with product after it has operated at least 24 hours with correct case temperature and proper control operation. When stocking the shelves, leave a gap between the product and the shelf above, which allows an air curtain on top of the product. Product should not extend beyond the front of the shelves or bottom wire rack. Do not exceed shelf load capacity (See Figure 32).

To unassemble a shelf, insert a putty knife between the side of the shelf and the shelf bracket. Pry the pieces apart to disengage the bracket.

Shelves can be ordered with 1", 2", or 3" acrylic product stops, which fit into aluminum price tag molding. Slide the product stop into the price tag molding and push it down to the bottom of the channel (See Figure 33). The channel of the price tag molding may need to be pried open with a screwdriver, but the product stop should slide in easily once started.

FIGURE 32: Shelf Load Capacities

SHELF TYPE	WIDTH	DEPTH	BRACKET TYPE	LOAD CAPACITY (LBS.)
Solid Shelf	24"	22"	2-Position (0°/10°)	350/150
			4-Position (0°/5°/10°/15°)	250/250/150/100
		24"	2-Position (0°/10°)	350/150
			4-Position (0°/5°/10°/15°)	250/250/150/100
		27"	2-Position (0°/10°)	350/150
		30"	22"	2-Position (0°/10°)
	4-Position (0°/5°/10°/15°)			250/250/150/100
	24"		2-Position (0°/10°)	350/150
			4-Position (0°/5°/10°/15°)	250/250/150/100
	27"		2-Position (0°/10°)	350/150
	48"		22"	2-Position (0°/10°)
		4-Position (0°/5°/10°/15°)		350/250/150/100
		24"	2-Position (0°/10°)	350/150
			4-Position (0°/5°/10°/15°)	350/250/150/100
27"		2-Position (0°/10°)	350/150	
Wire Shelf		30"	22"	2-Position (0°/10°)

FIGURE 33: Acrylic Product Stops (1" Shown)



Product stop fits into the price tag molding.

REFRIGERATION

⚠ WARNING! REFRIGERATION SYSTEMS USING R-744 (CO₂) ARE UNDER HIGH PRESSURE. DO NOT TAMPER WITH THE SYSTEM. CONTACT QUALIFIED SERVICE PERSONAL BEFORE DISPOSAL.

Mechanical Components

EVAPORATOR FANS

Air is circulated through the display case by fans. The fans are located above the false ceiling panel, and they can be accessed by removing the screws holding the false ceiling panel. Air enters from the top front air grille, and air is discharged down the rear ducts.

EXPANSION VALVE

FIGURE 34: Fan and Expansion Valve

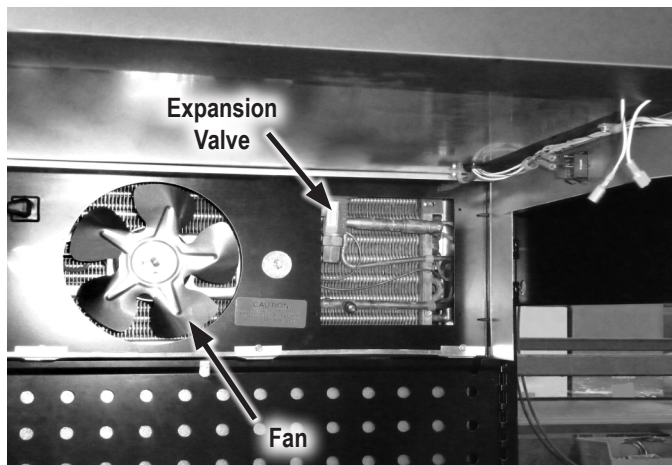
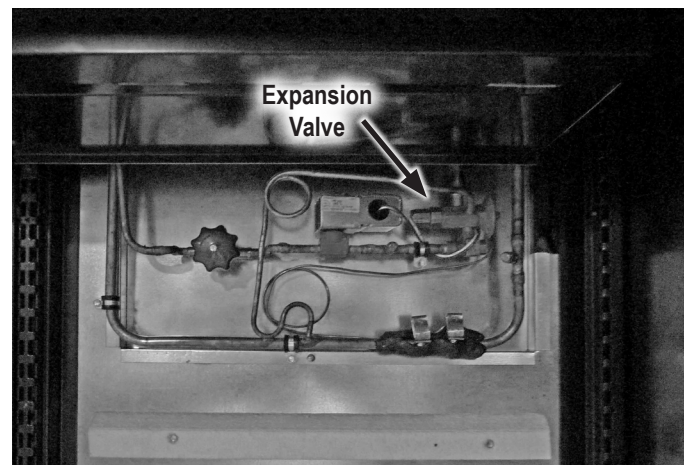

FIGURE 35: Alternate Expansion Valve Location



Typically, the expansion valve is located behind the false ceiling panel in the right-most door of each case. After removing the false ceiling panel, you will see a rectangular cover panel. Remove the cover panel to access the expansion valve and suction line Schrader valve (See Figure 34). Alternatively, the expansion valve may be located behind the optional right back duct per customer request. An access cover is provided in the duct (See Figure 35).

ADDITIONAL VALVES

Glycol cases typically have a balance valve located in the outlet line on the top of the case. If a stop solenoid is provided, it will also be located in the outlet line on top of the case. Schrader taps are provided inside the case on the right-hand side of the coil for venting and draining the system. An additional tap is provided on top of the case to allow for venting when the system is drained.

Refrigerant Piping

The display case must be connected to a refrigeration unit using the same refrigerant indicated on the display case serial tag.

Correct refrigeration line sizing and industry standard installation practices are essential for proper system operation. Zero Zone offers many refrigerant choices. We recommend using the Sporlan Virtual Engineer Toolbox to calculate sizing for liquid, suction, and discharge lines: <https://solutions.parker.com/sporlanvirtualengineer>. Go to the link, select the line type, and then enter the information required to calculate the recommended line size. Toggle between metric or imperial units as needed.

REFRIGERATION

Leak Check, Evacuation, & Charging

After all of the refrigeration piping and system components have been assembled, the entire system must be pressurized and checked for leaks. When the system is leak free, evacuate with a deep vacuum pump. Triple evacuation should be done to 500 microns or less, and nitrogen sweep is recommended. After the system has been thoroughly evacuated of all moisture and non-condensable gas, charge the system with the specified refrigerant.

Operation Set Points

Refer to the case spec sheet for btu/h requirements and electrical requirements. Operate the case at the following settings to maintain product temperature of 41°F or below, per food safety regulations (**See Figure 36**).

FIGURE 36: Case Temperature Internal Control Options

SETTING	COOLER		
Evaporator Temp	28°F		
Return Air Temperature Set Point	33°F		
Return Air Temperature Differential	4°F		
Discharge Air Temperature Set Point	30°F		
Discharge Air Temperature Differential	4°F		
SETTING	R-404A	R-448A	Sat. Temp
Condensing Unit Cut-In	74 psig	62 psig	33°F
Condensing Unit Cut-Out	62 psig	51 psig	25°F
<p>Note: Set points based on superheat of 6-8°F. For high-glide refrigerants, use dew point for unit sizing. Adjust evaporator pressure as needed to maintain discharge air temperature. To receive the full benefit of high-glide refrigerant properties, the superheat may need to be lowered to 4-6°F. Contact Zero Zone with questions.</p>			

Defrost

Crystal Merchandiser® coolers can be set up with either off-cycle defrost or electric defrost. **See Figure 37** for defrost settings.

FIGURE 37: Defrost Settings

SETTING	COOLER	
Defrost Type	Off-Cycle	Electric
Frequency	3 Per Day	2 Per Day
Duration	45 Minutes	30 Minutes

Case Thermometers

The cases are shipped with 2 thermometers. One thermometer is factory-mounted to sense the discharge air stream (rear duct). A second NSF thermometer is shipped loose and should be installed in the warmest product location as required by NSF. Specific field installation instructions are packaged with the NSF thermometer.

ELECTRICAL

General

CAUTION! DISCONNECT POWER TO THE CASE BEFORE SERVICING ELECTRICAL COMPONENTS TO AVOID PERSONAL INJURY AND DAMAGE TO THE UNIT.

Cases may have 2 or 3 electrical circuits. Standard cases have 2 electrical circuits: the fan circuit and the lighting circuit. Cases may be purchased with heated doors, which add an additional electric circuit.

The electrical box is mounted on the exterior top right of the case. The box includes the power connection and power supplies for the LED light sticks. The light switch is located on the interior ceiling to the right of the coil cover (See Figure 38).

Black and white wires and wire nuts are supplied, and the wire nut must be connected inside the electrical box. A ground connection should also be connected inside the electrical box. **Always refer to the wiring diagram shipped with the case (See Figure 39).**

External wiring should be sized according to the amperage rating stamped on the serial tag, which is located on the ceiling inside the left-hand door. Typical electrical values are shown on specification sheets that are available online. All internal wiring has been completed at the factory.

All wiring must comply with the National Electrical Code (NEC) and all local codes. After installing the equipment, correct operation of the electrical circuits, controls, and defrost controls should be verified. All operating voltages and amperages should be measured and recorded. Display cases that do not include a remote disconnect must be field installed with a remote disconnect in accordance with NFPA 7.0 of the National Electric Code.

FIGURE 38: Light Switch



FIGURE 39: Sample Wiring Diagram

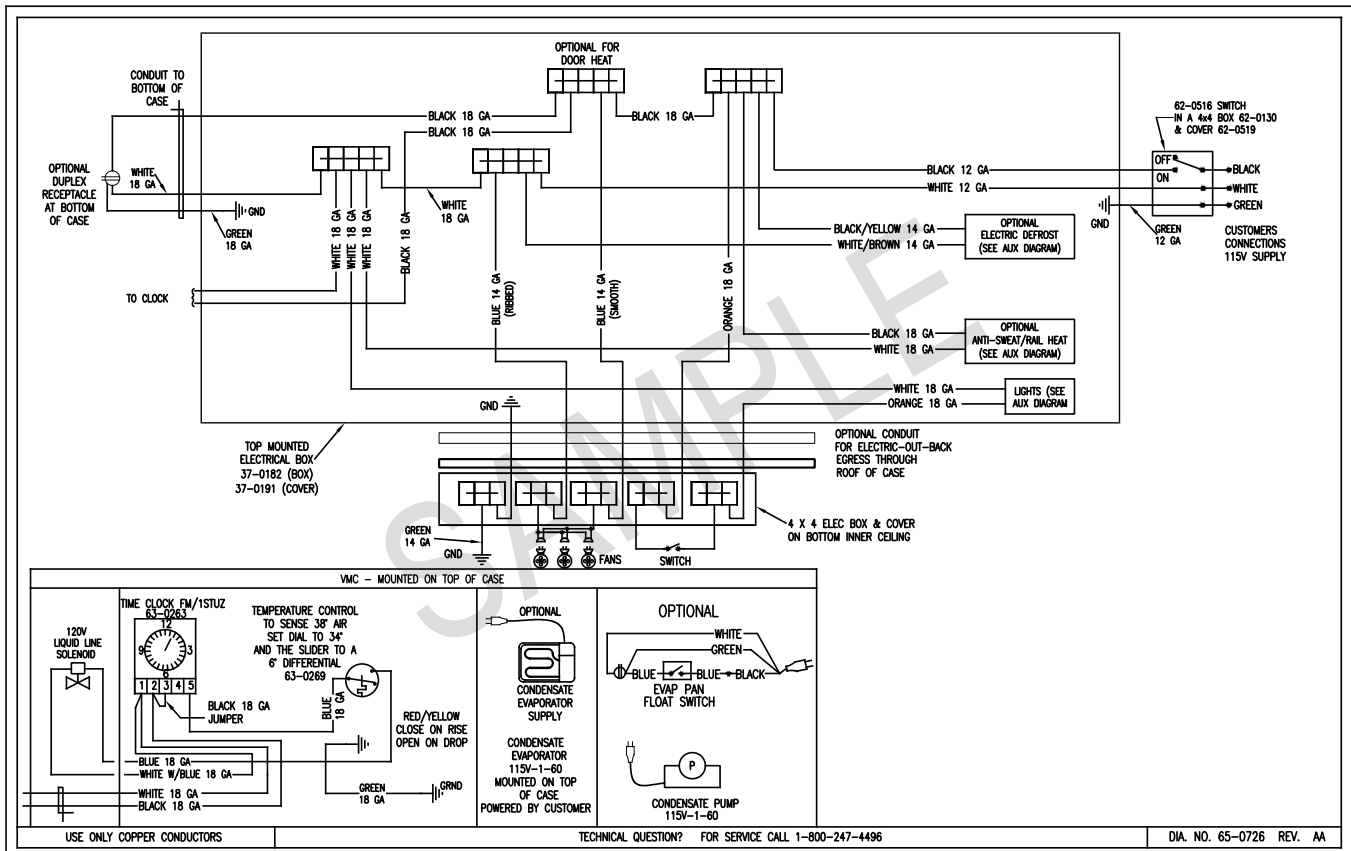

MAINTENANCE

Cleaning

Although each Zero Zone display case is thoroughly cleaned before shipping, the cases should be thoroughly cleaned again before start-up and routinely thereafter to maintain a clean appearance. With just a few minutes of cleaning each week, the case will remain in top condition.

1. Do not use high-pressure water or steam to clean the interior or any components.
2. Do not wash fan motors. A damp cloth can be used to wipe the fan motors. Cover the fan motors with a plastic bag when washing the case.
3. Wipe out the case interior using mild detergent and warm water (never an abrasive cleaner).
4. Clean all glass doors, windowed ends, and mirrors using glass cleaner. Cleaning interior glass reduces fogging and increases visibility. Do not use any cleaning products containing silicon for anti-fog.
5. The drain pan can be flushed after removing bottom wire racks. The coil can be cleaned after removing the false ceilings, fans, and fan plenums.
6. If the case is equipped with a condensate pan and pump, the drain should be blocked before washing coils. Water can be removed with a shop vacuum.
7. Coils may be cleaned with a garden hose or pails of water. If the case is equipped with a condensate pan and pump, cases should be cleaned with a minimal amount of water so the evaporator, pump, and drain pans do not get overfilled.
8. The case drain should frequently be cleaned of debris and price tags to prevent clogging. If water is rising, check if the drain is clogged.

UNDER CASE FLOOR CLEANING (NSF)

The floor under your Zero Zone display case can be cleaned by following these steps:

1. Remove the fasteners attaching the kickplate to the case. The fasteners are accessed from the front of the unit.
2. With the kickplates removed, remove debris from the floor.
3. Vacuum under the case to remove any dirt, debris, and dust build-up.
4. Mop under the unit using non-abrasive floor cleaner and warm water.
5. When finished mopping, squeegee any remaining water under the unit to the floor drains to speed up the drying process. Replace the kickplates when the floor has dried.



For other technical support, please refer to
the Technical Resources page at:

WWW.ZERO-ZONE.COM

or contact the Zero Zone Service Department at:

800-247-4496

All specifications subject to change without notice.

